

16-B. ABS (After '95)

Service Information	16-B-1	Troubleshooting	16-B-5
System Location	16-B-2	Wheel Speed Sensor Air Gap Inspection	16-B-34
System Wiring Connections/Locations	16-B-3	Front Modulator Removal/Installation	16-B-36
Circuit Diagram	16-B-4	Rear Modulator Removal/Installation	16-B-38

Service Information

CAUTION

- Use a fully charged battery for troubleshooting. Do not diagnose the ABS with a charger connected to the battery.
- On removal and installation of the wheels and wheel speed sensors, be careful not to damage the wheel speed sensors and pulser rings.

NOTE

- Check the following before performing any ABS troubleshooting.
 - Pre-start self-diagnosis of ABS
 - ABS indicator lightIf an abnormality is found during the above checks, perform the ABS troubleshooting following the Symptom-to-System Chart (page 16-B-8). The ABS is normal if no trouble is found. Go to the checks on the other systems (e.g., LBS or basic brake system).
- Troubles not resulting from a faulty ABS, i.e. brake disc squeak, unevenly worn brake pad, etc., cannot be recognized by the ABS diagnosis system. (See the Common Service Manual.)
- Record the symptom of the problem and the problem code in MEMO before troubleshooting.
- When the ABS is faulty, the ABS indicator light blinks or it comes on. The ABS does not function at this time; take care during the test ride.
- Do not disassembly the modulator assembly. If it is faulty, replace it an assembly.
- Refer to page 15-2 for brake fluid filling and bleeding. Note that there is no brake fluid in the modulator (except in the modulator head), because the modulator is the motor-driven hydraulic pressure type. Therefore, brake fluid replacement and bleeding air from the modulator body is not necessary.
- When the wheel is removed, perform the air gap inspection (page 16-B-51).
- The ABS indicator light might blink in the following cases. If the indicator light blinks, clear the problem code and perform the pre-start self-diagnosis of the ABS (page 16-5). The ABS is normal if the ABS indicator light goes off.
 - The motorcycle has continuously run on the bumpy road.
 - The ABS control unit (ECU) was disrupted by extremely powerful radio were (Electromagnetic Interference).
 - After riding (i.e. after the pre-start self-diagnosis), the engine was kept running and the rear wheel turning (for more than 30 seconds) with the motorcycle on the center stand.
- The ABS indicator light might blink in the following cases. If the indicator light blinks, service the faulty parts, clear the problem code, and perform the pre-start self-diagnosis of the ABS (page 16-B-5). The ABS is normal if the ABS indicator light goes off.
 - Incorrect tire pressure
 - Tires not recommended for the motorcycle were installed.
 - Deformation of the wheel
- After troubleshooting, clear the problem code and perform the pre-start self-diagnosis again to be sure that the ABS indicator light is operating normally.

System Location

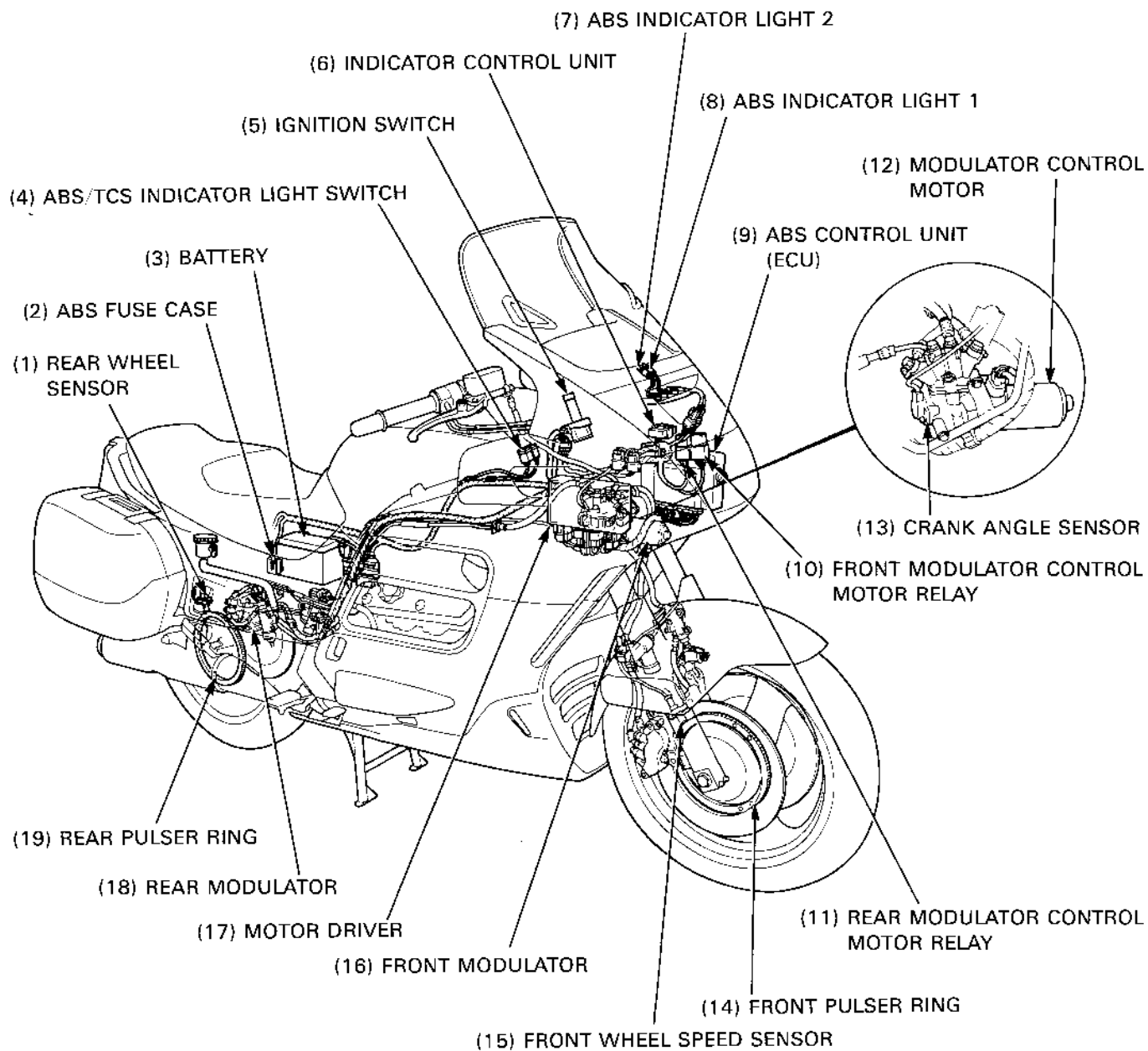

System Wiring Connections/Locations

Refer to section 2, for the parts that must be removed for service.

For example: ① CRANK ANGLE SENSOR ← Maintenance part

-R. side cover (page 2-2) ← The parts that must be removed for service

- ① REAR MODULATOR
CRANK ANGLE SENSOR
-R. side cover (page 2-2)

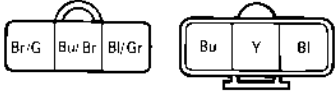

- ② ABS/TCS INDICATOR
LIGHT SWITCH
-Top shelter
(page 2-5)

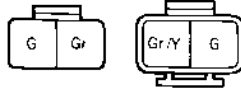

- ③ INDICATOR CONTROL
UNIT
-L. fairing pocket
(page 2-6)

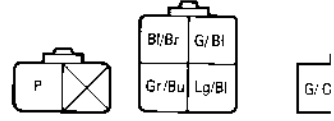

ABS MAIN (30A)

FRONT MODULATOR
CONTROL MOTOR
(10A)

REAR MODULATOR
CONTROL MOTOR
(10A)

ABS FUSE CASE
-L. side cover (page 2-2)

Bl ... BLACK	Br ... BROWN
Y ... YELLOW	O ... ORANGE
Bu ... BLUE	Lb ... LIGHT BLUE
G ... GREEN	Lg ... LIGHT GREEN
R ... RED	P ... PINK
W ... WHITE	Gr ... GRAY



- ⑬ REAR MODULATOR CONTROL MOTOR
-R. side cover (page 2-2)



- ⑭ REAR WHEEL SPEED SENSOR
-R. side cover
(page 2-2)

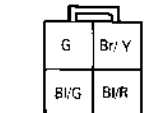
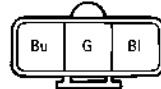

- ⑮ MOTOR DRIVE
(4P Blue)
-Upper fairing
(page 2-9)

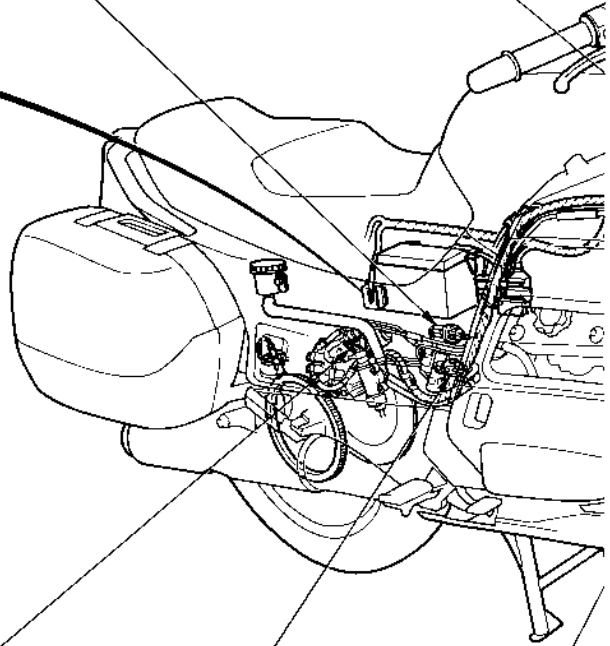

④ ABS INDICATOR LIGHT 1
-Inner screen
(page 2-7)



⑤ ABS INDICATOR LIGHT 2
-Inner screen
(page 2-7)



⑥ INDICATOR (Black)
-Inner screen
(page 2-7)

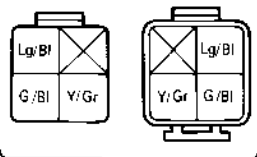

⑦ INDICATOR (White)
-Inner screen (page 2-7)

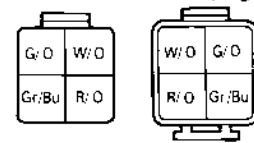

⑧ FRONT MODULATOR CONTROL MOTOR RELAY - Upper fairing
(page 2-9)

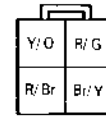

⑨ REAR MODULATOR CONTROL MOTOR RELAY - Upper fairing
(page 2-9)



⑩ FRONT MODULATOR CRANK ANGLE SENSOR - Upper fairing (page 2-9)

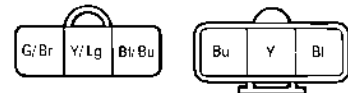

⑪ FRONT WHEEL SPEED SENSOR - Upper fairing (page 2-9)

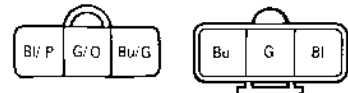

⑫ ECU (Black)
-Upper fairing (page 2-9)

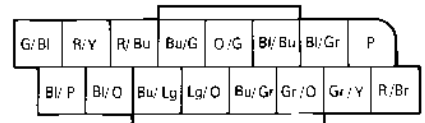

⑬ ECU (White)
-Upper fairing (page 2-9)

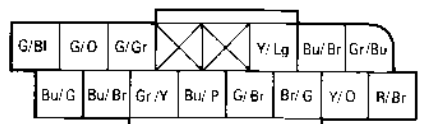

⑭ MOTOR DRIVER (12P)
-Upper fairing
(page 2-9)



⑮ MOTOR DRIVER (4P Black)
-Upper fairing
(page 2-9)



⑯ FRONT MODULATOR CONTROL MOTOR
-Upper fairing (page 2-9)

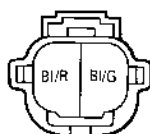

Circuit Diagram

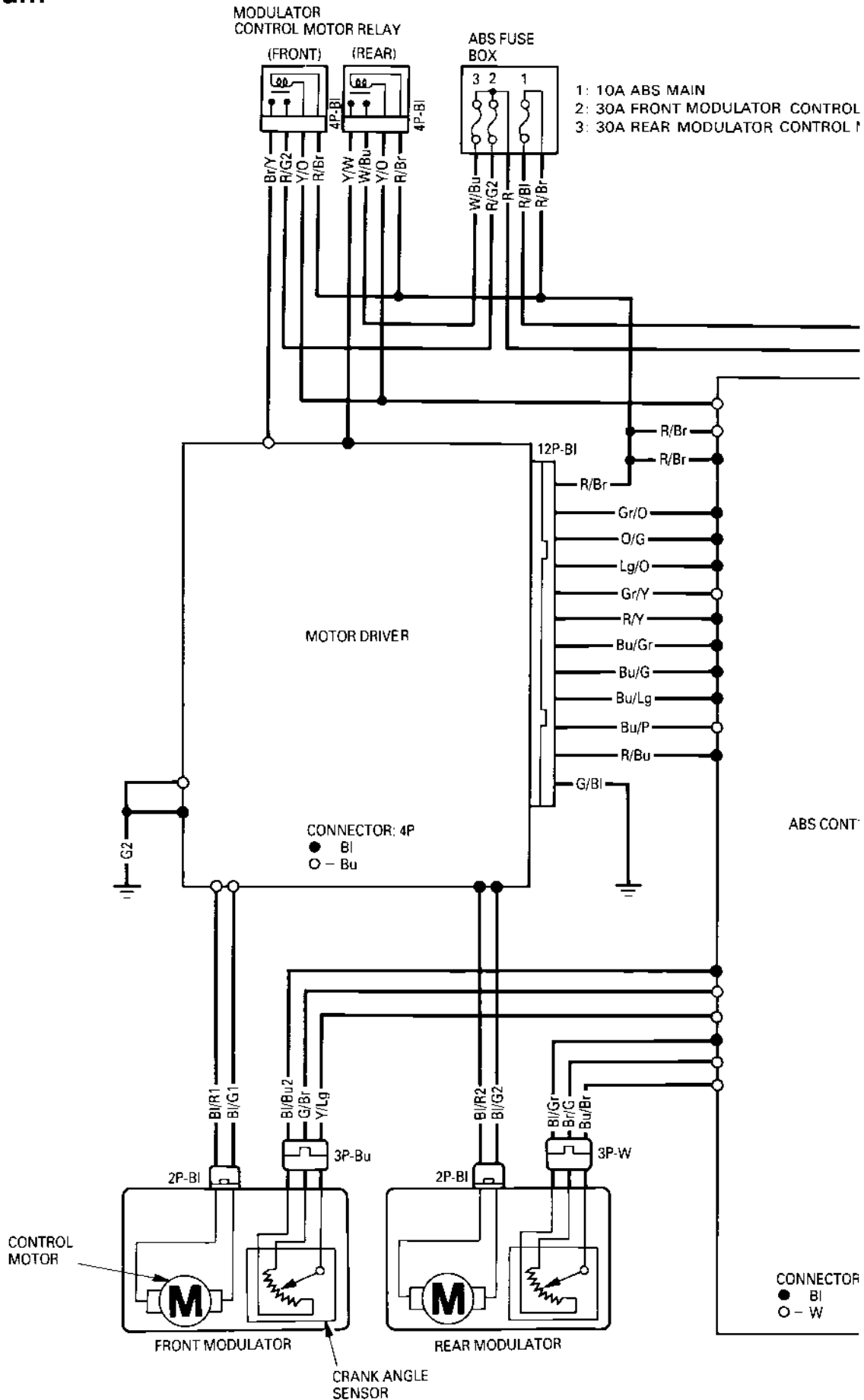

- | | | | | | |
|----|-------|--------|----|-------|-------------|
| Bl | | BLACK | Br | | BROWN |
| Y | | YELLOW | O | | ORANGE |
| Bu | | BLUE | Lb | | LIGHT BLUE |
| G | | GREEN | Lg | | LIGHT GREEN |
| R | | RED | P | | PINK |
| W | | WHITE | Gr | | GRAY |

MOTOR
MOTOR

CONTROL UNIT (ECU)

16P

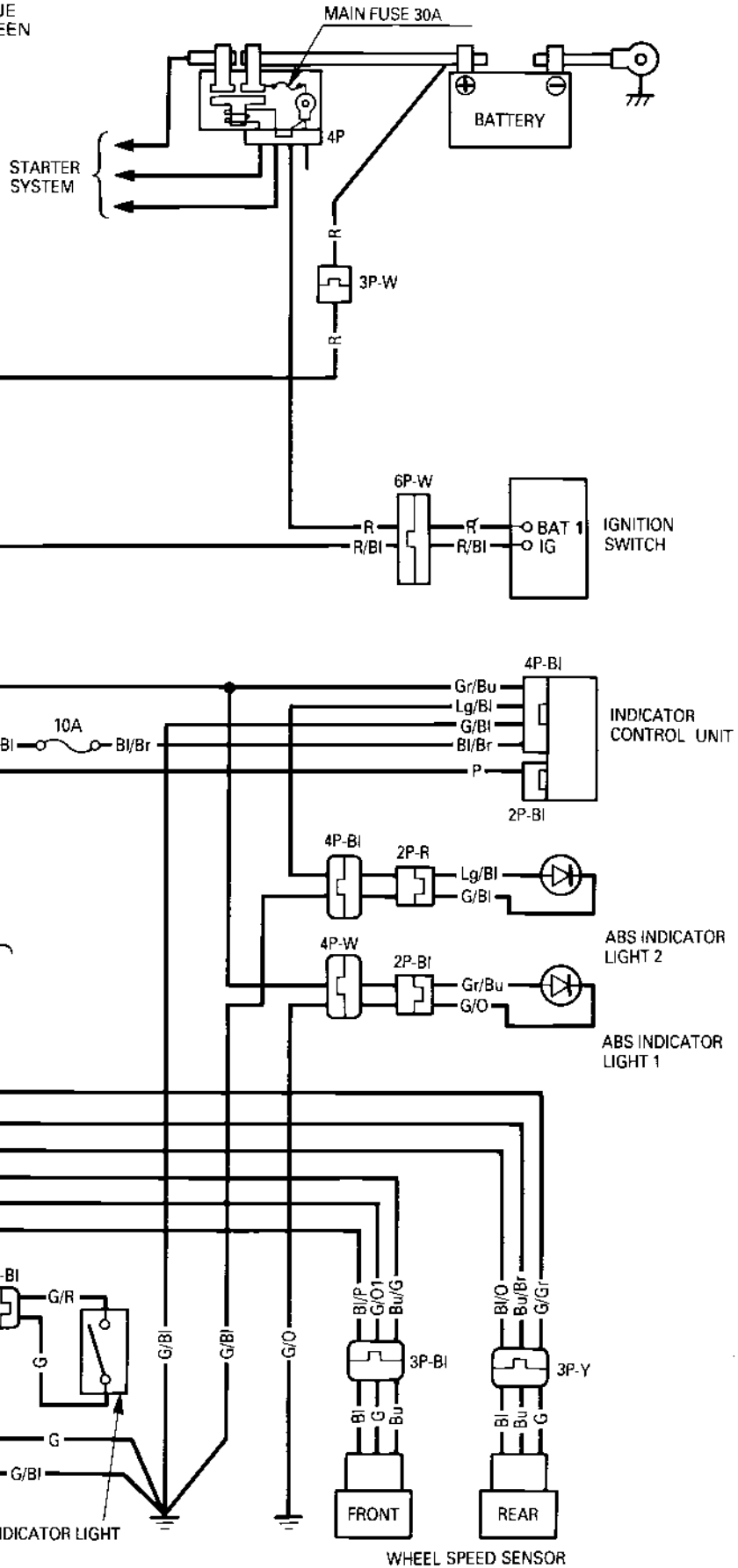

Troubleshooting

Before Beginning Troubleshooting

Summary of ABS pre-start self-diagnosis system

The ABS pre-start self-diagnosis system diagnoses the electrical system as well as the operating status of the modulator. When there is any abnormality, the problem and the problem part can be detected by outputting the problem code.

When the vehicle speed is approximately 10 km/h (6 mile/h) or more, the wheel speed sensor signal is input to the ABS control unit (ECU), then the ABS pre-start self-diagnosis system operates the control motor inside the modulator, checks the crank angle condition with ABS control unit (ECU) and thereby it detects whether the modulator operation is normal, and it completes the pre-start self-diagnosis.

When the ABS is normal, the ABS indicator light goes off just after starting up indicating that the diagnosis is completed. If a problem is detected, the ABS indicator light blinks or comes on and stays on to notify the rider of the problem. The self-diagnosis is also made while the motorcycle is running, and the indicator light blinks when a problem is detected. When the indicator light blinks, the cause of the problem can be identified by retrieving the problem code following the specified retrieval procedure. (page 16-B-6)

PRE-START SELF-DIAGNOSIS WHEN NORMAL

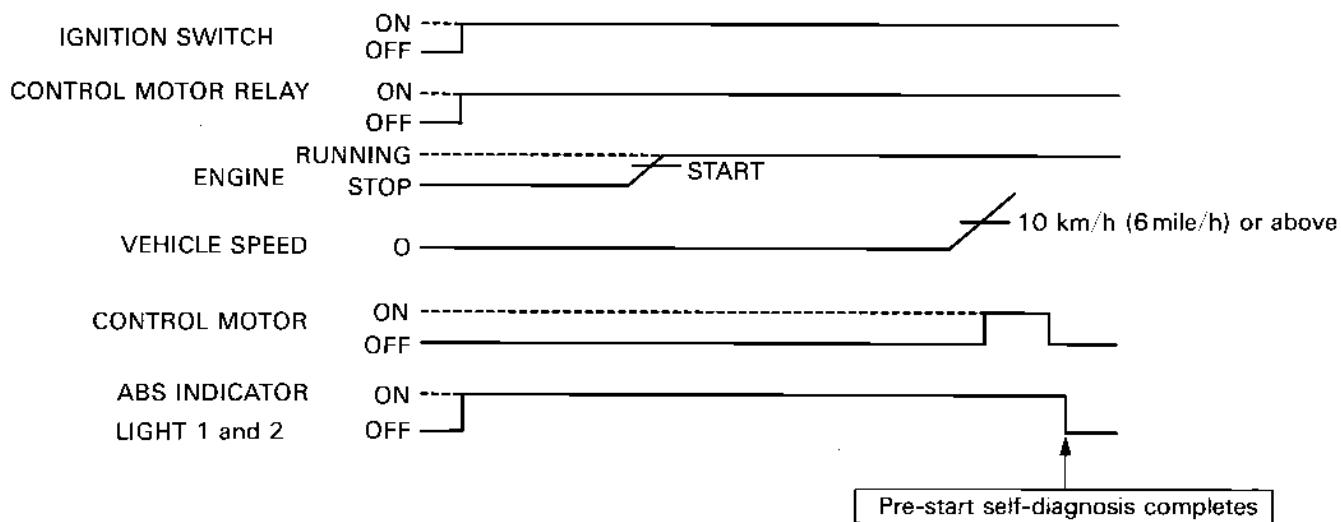

Pre-start self-diagnosis procedure (Everyday check-up)

1. Turn the ignition switch ON.
2. Be sure that the ABS indicator lights 1 and 2 come ON.
3. Start the engine.
4. Ride the motorcycle and raise the vehicle speed to approximately 10 km/h (pre-start self-diagnosis completes).
5. The ABS is normal if both the ABS indicator light 1 and 2 go OFF.

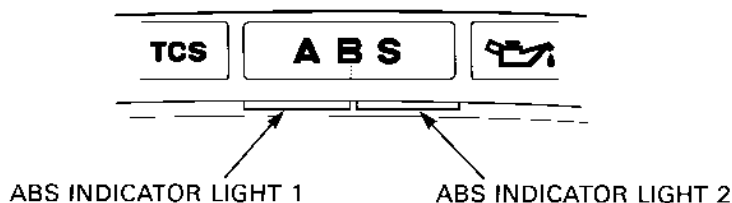

Retrieval of/Clearing Problem Code

NOTE

- The ABS indicator light indicates the problem code by its number of blinks (see the next page).
- The problem code is not cleared when the ignition switch is turned OFF during output of the problem code. However, output cannot be restarted by turning the ignition switch ON. Restart the output following the problem code retrieval procedure.
- After retrieving the problem code, be sure to record it in MEMO, etc. Clear the problem code after troubleshooting.

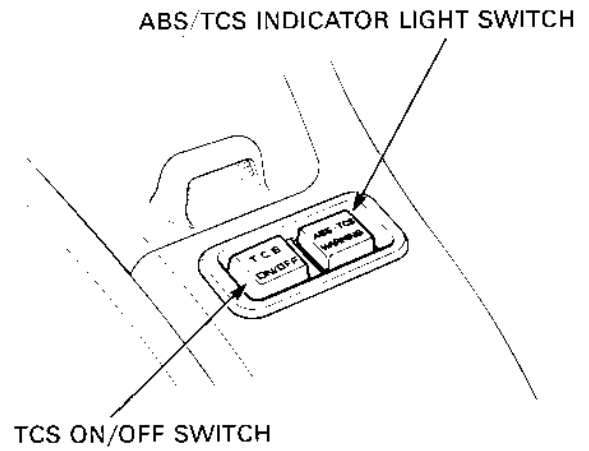

Retrieval:

1. Turn the ignition switch OFF.
 2. Turn the ignition switch ON while pressing the ABS/TCS indicator light switch. The ABS indicator light 1 and 2 should come ON. (The ABS indicator light 2 is OFF this time.)
 3. Hold the ABS/TCS indicator light switch pressed (for approximately 5 seconds). The ABS indicator light 1 should go OFF.
 4. Release the ABS/TCS indicator light switch immediately (within 1 second) after the ABS indicator light go OFF.
- ⇨ Output of the problem code starts and the ABS indicator light 1 blinks.



Clearing:

5. Press the ABS/TCS indicator light switch during output of the problem code (while the ABS indicator light is blinking).
- ⇨ The Problem code is cleared and the ABS indicator light 1 and 2 comes ON and stay ON.

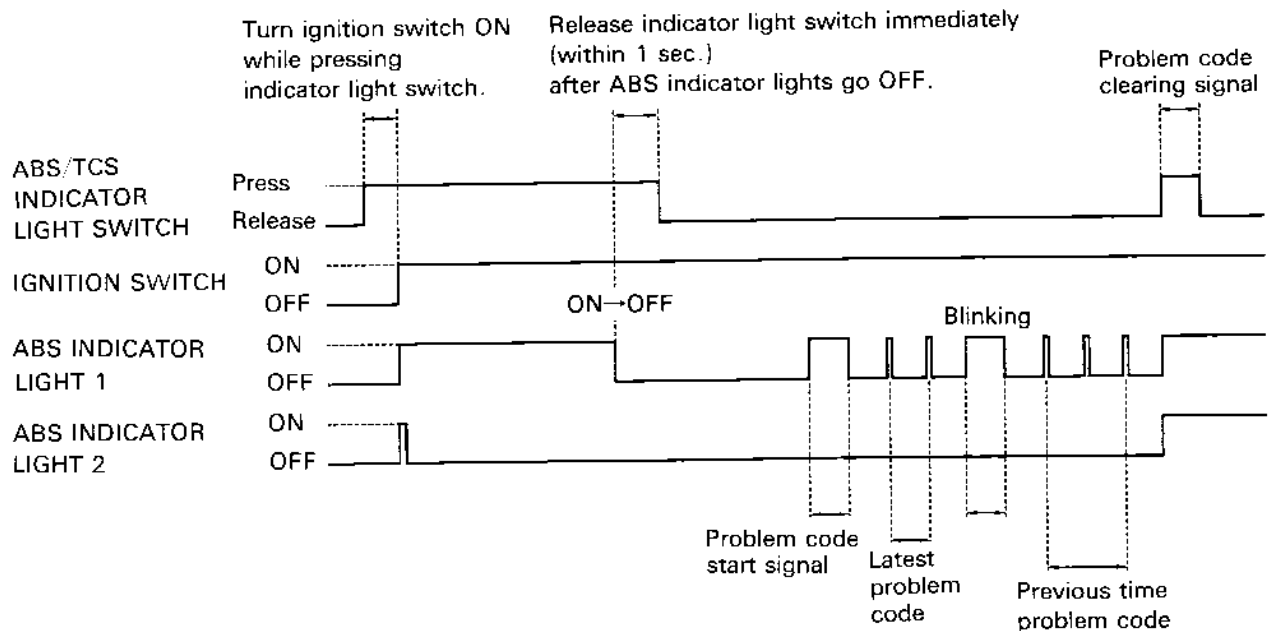

Problem code indication pattern

Example:

- When the problem code is stored;

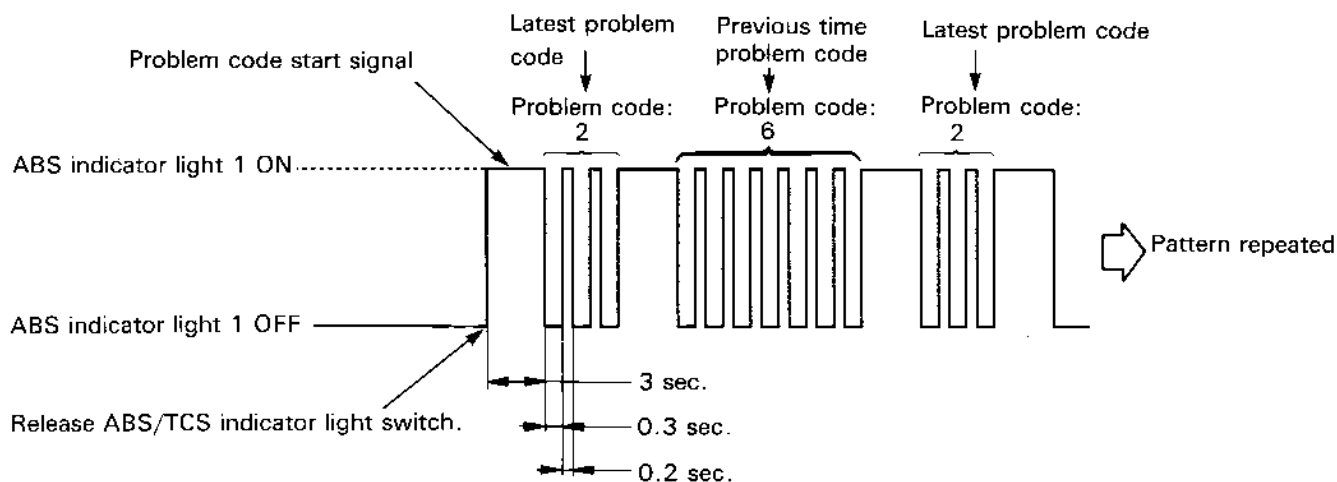

- When the problem code not stored;

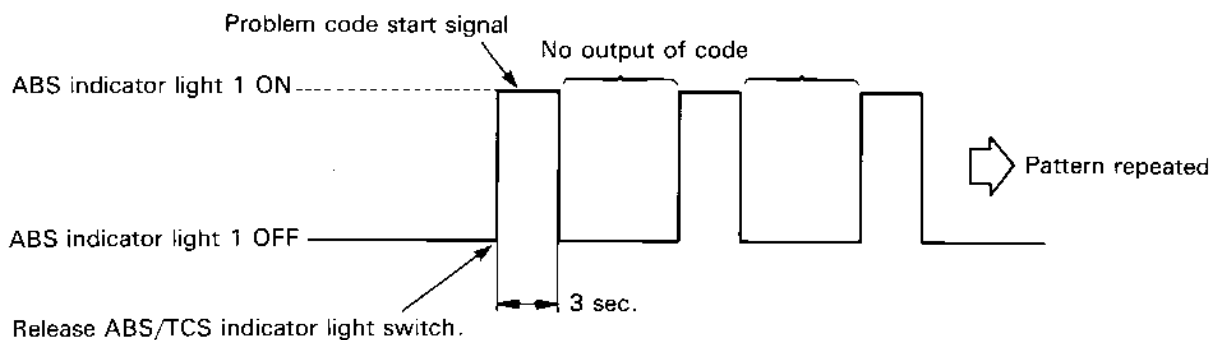

NOTE

- The ECU can store up to two problem codes. The latest problem code is output first, then the previous one is output. When the two problem codes are output, diagnose on the latest problem code (i.e. code output first).
- After troubleshooting, perform the pre-start self-diagnosis again to be sure that there is no problem in the ABS indicator lights and the problem code is cleared.
- See page 16-B-33 for the problems that are not represented with the problem codes.
- Check the following before performing ABS troubleshooting:
 - Pre-start self-diagnosis of ABS
 - ABS indicator light

If an abnormality is found during the above checks, perform the ABS troubleshooting following the Symptom-to-System Chart (see the following page). The ABS is normal if no trouble is found. Go on to check the other basic systems (e.g., LBS or basic brake system).

Symptom-to System Chart

Problem		Affected																			
Problem code	Item	Fuse		Modulator				Modulator control motor relay		Motor driver		Wheel speed sensor		Pulser ring		Power circuit (charging)	Wire harness	ABS control unit (ECU)	ABS indicator light	Indicator control unit	Reference page
		ABS main	Modulator control motor	Control motor		Crank angle sensor	Front	Rear	Front	Rear	Front	Rear	Front	Rear							
				Front	Rear																
①	Faulty front modulator crank angle sensor system					○														16-B-9	
②	Faulty rear modulator crank angle sensor system						○													16-B-12	
③	Faulty front modulator control motor system		○	○						○										16-B-15	
④	Faulty rear modulator control motor system			○	○					○										16-B-19	
⑤	Faulty front wheel speed sensor system										○		○							16-B-23	
⑥	Faulty rear wheel speed sensor system											○		○						16-B-26	
⑦	Faulty power circuit														○					16-B-29	
⑧	Faulty ABS control unit (ECU)					○	○			○										16-B-31	
↙	Problems not recognized by ABS control unit (ECU)	○														○				16-B-33	

NOTE

- Check the following before performing ABS troubleshooting.
 - Pre-start self-diagnosis of ABS (page 16-B-5)
 - ABS indicator light (page 16-B-5)
 If an abnormality is found during the above checks, perform the ABS troubleshooting following the Symptom-to-System Chart. The ABS is normal if no trouble is found. If no trouble is found, continue on to the other system checks (e.g., LBS or basic brake system).
- After troubleshooting, clear the problem code (page 16-B-6) and perform the pre-start self-diagnosis again (page 16-B-5) to be sure that the ABS indicator light is operation properly.

Flowcharts

CAUTION

- Use a fully charged battery. Do not diagnose with a charger connected to the battery.

NOTE

- Turn the ignition switch OFF unless otherwise specified.
- When the ABS control unit (ECU), motor driver or modulator is detected to be faulty, recheck the wire harnesses and connectors connections closely before replacing the control unit, motor driver or modulator.
- After troubleshooting, perform the pre-start self-diagnosis again and be sure that the ABS indicator light is normal.
- The encircled numbers in the texts and connector diagrams indicate the connectors (see page 16-B-3). All connectors diagrams in the text are view from the terminal side.

Problem code 1: Faulty front modulator crank angle sensor system

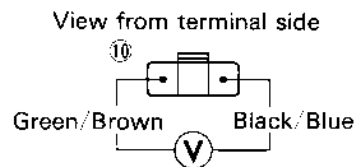
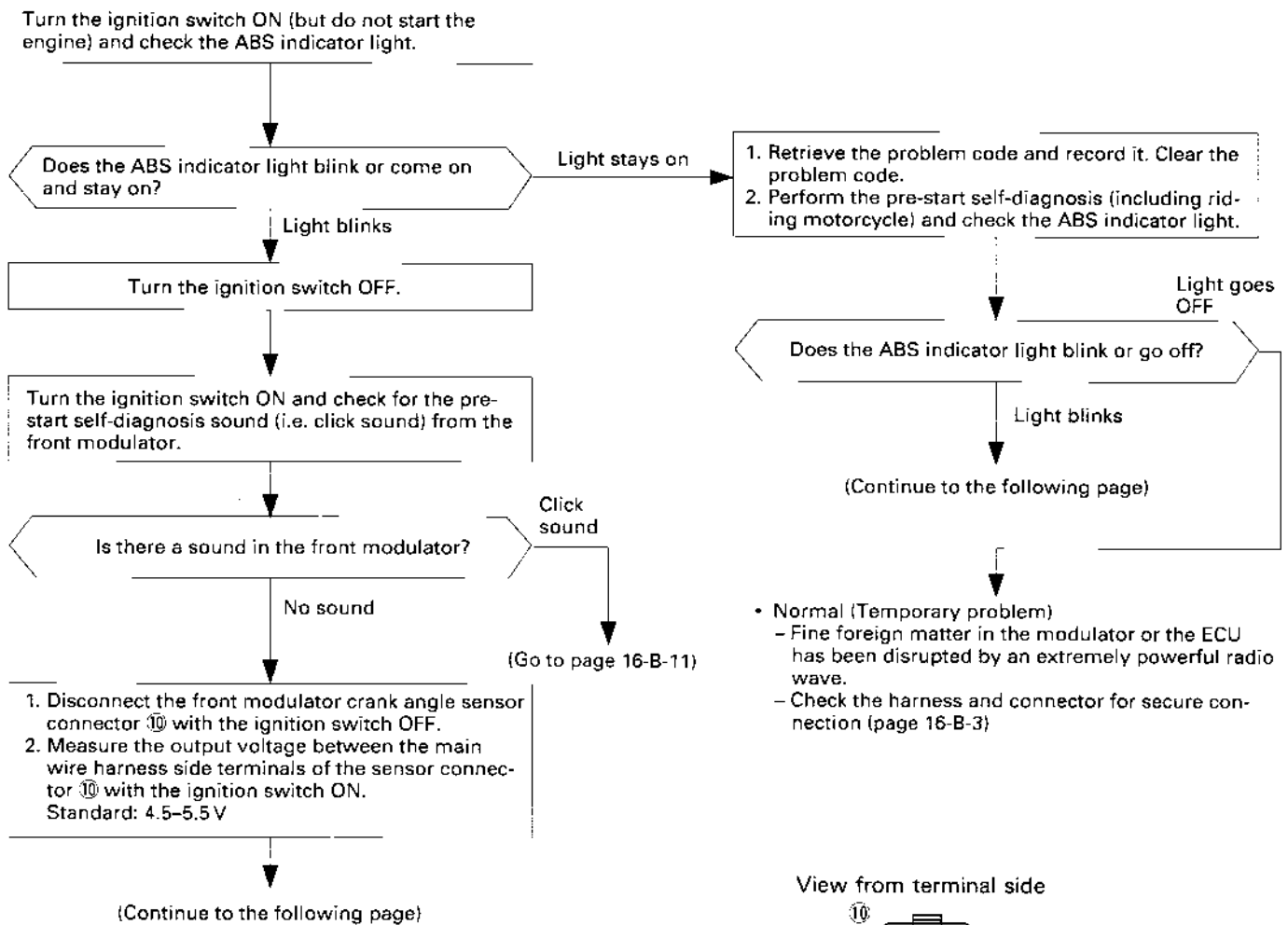

(From the previous page: Measure the output voltage at the 10 connector)

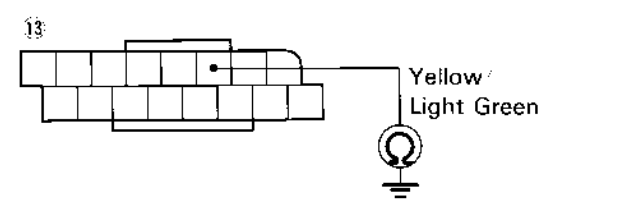
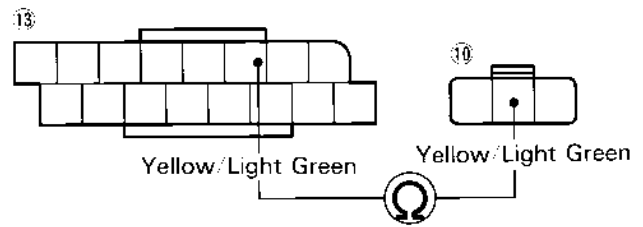
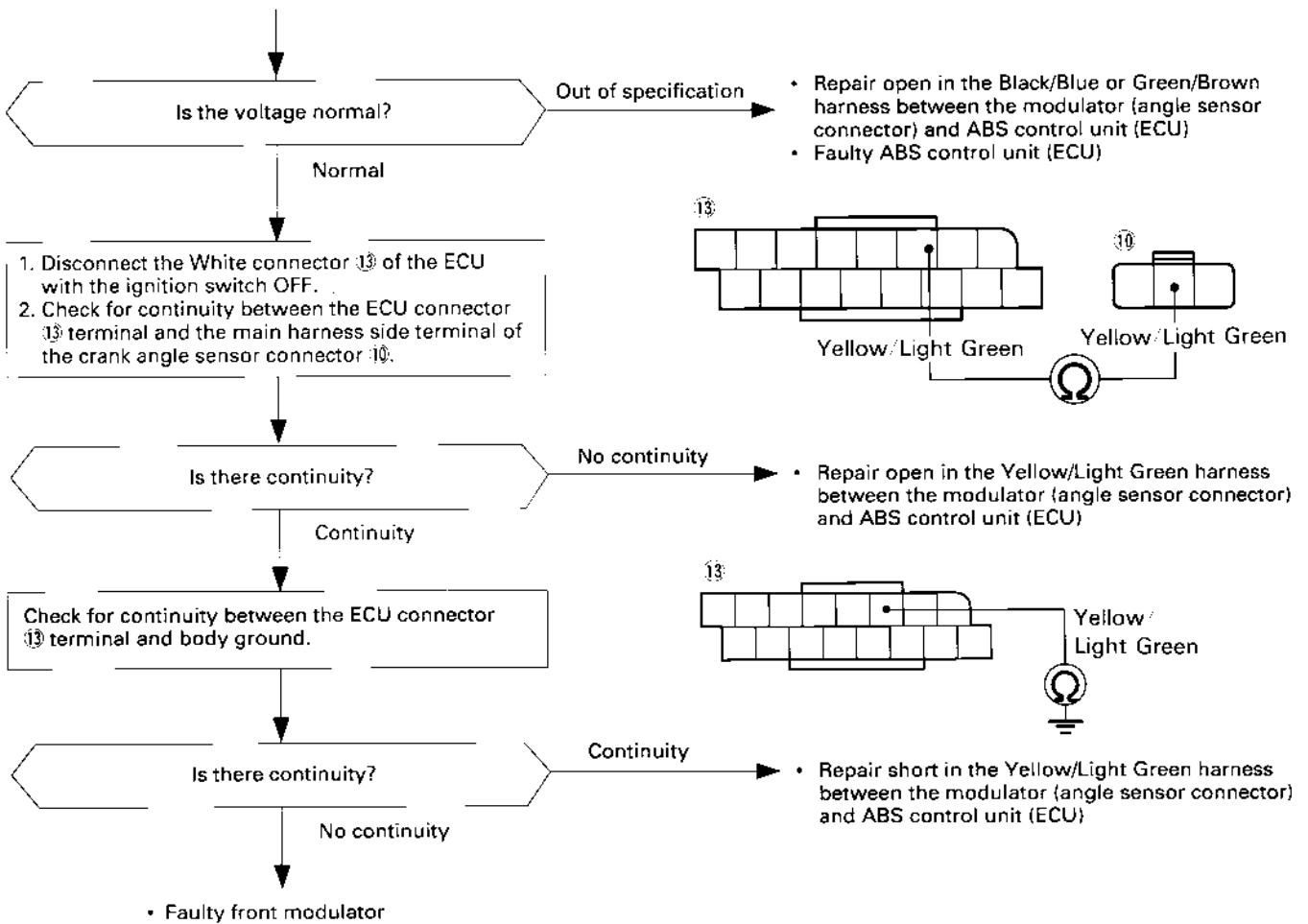

(From the previous page: Light blinks)

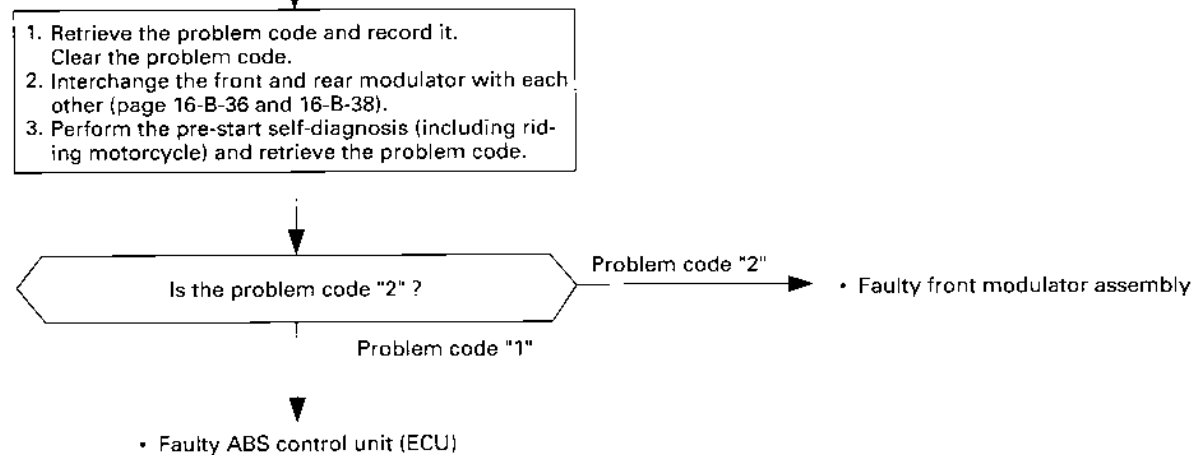

(From page 16-B-9: Click sound)

1. Disconnect the front modulator control motor relay connector ⑧ and connect the headlight relay instead with the ignition switch OFF.
2. Turn the ignition switch ON and check the ABS indicator light.

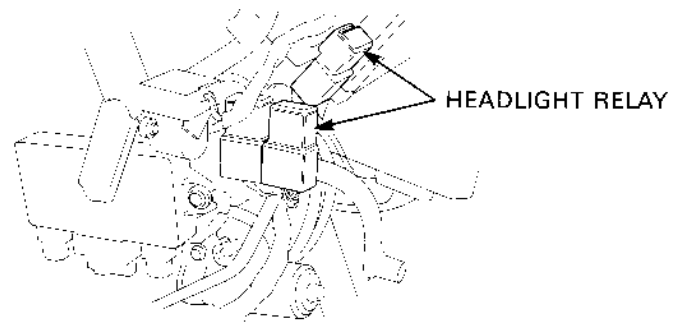

Does the ABS indicator light blink or come on and stay on?

Light stays on

- Faulty front modulator control motor relay

Light blinks

1. Disconnect the front and rear modulator control motor relay connector ⑧/⑨ and ECU White connector ⑬ with the ignition switch OFF.
2. Check for continuity between the connector ⑧ terminal and body ground.

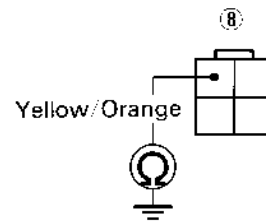

Is there continuity?

Continuity

- Repair short in the Yellow/Orange harness between the front/rear modulator control motor relay and ABS control unit (ECU).

No continuity

- Faulty ABS control unit (ECU)

(From the previous page: Normal)

1. Disconnect the White connector ⑬ of the ECU with the ignition switch OFF.
2. Check for continuity between the ECU connector ⑬ terminal and the main harness side terminal of the crank angle sensor connector ①.

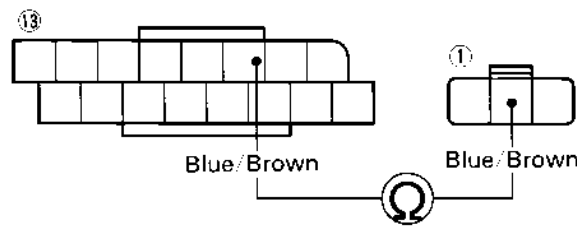

Is there continuity?

- No continuity → • Repair open in the Blue/Brown harness between the modulator (connector angle sensor) and ABS control unit (ECU)

Continuity

- Check for continuity between the ECU connector ⑬ terminal and body ground.

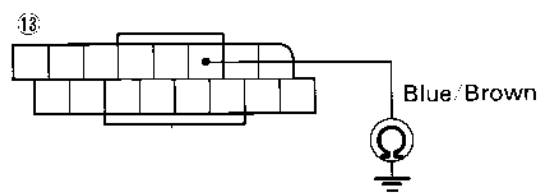

Is there continuity?

- Continuity → • Repair short in the Blue/Brown harness between the modulator (angle sensor connector) and ABS control unit (ECU)

No continuity

• Faulty rear modulator

(From the previous page: Light blinks)

1. Retrieve the problem code and record it. Clear the problem code.
2. Interchange the front and rear modulator with each other (page 16-B-36 and 16-B-38).
3. Perform the pre-start self-diagnosis (including riding motorcycle) and retrieve the problem code.

Is the problem code "1" ?

- Problem code "1" → • Faulty rear modulator assembly

Problem code "2"

• Faulty ABS control unit (ECU)

(From page 16-B-12: Click sound)

1. Disconnect the rear modulator control motor relay connector ⑨ and connect the headlight relay instead with the ignition switch OFF.
2. Turn the ignition switch ON and check the ABS indicator light.

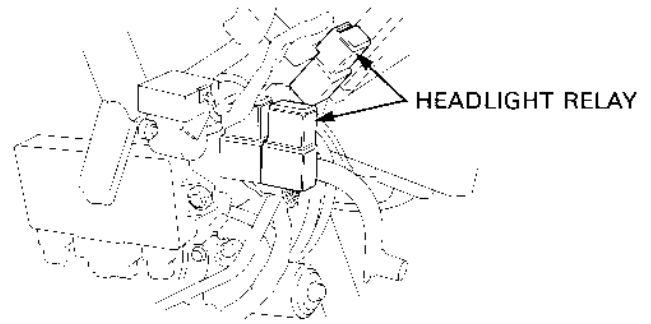

Does the ABS indicator light blink or come on and stay on?

Light stays on

- Faulty rear modulator control motor relay

Light blinks

1. Disconnect the front and rear modulator control motor relay connector ⑧/⑨ and ECU White connector ⑬ with the ignition switch OFF.
2. Check for continuity between the connector ⑨ terminal and body ground.

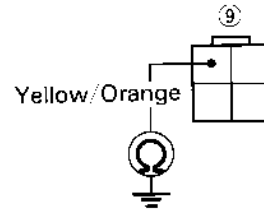

Is there continuity?

Continuity

- Repair short in the Yellow/Orange harness between the front/rear modulator control motor relay and ABS control unit (ECU).

No continuity

- Faulty ABS control unit (ECU)

Problem code 3: Faulty front modulator control motor system

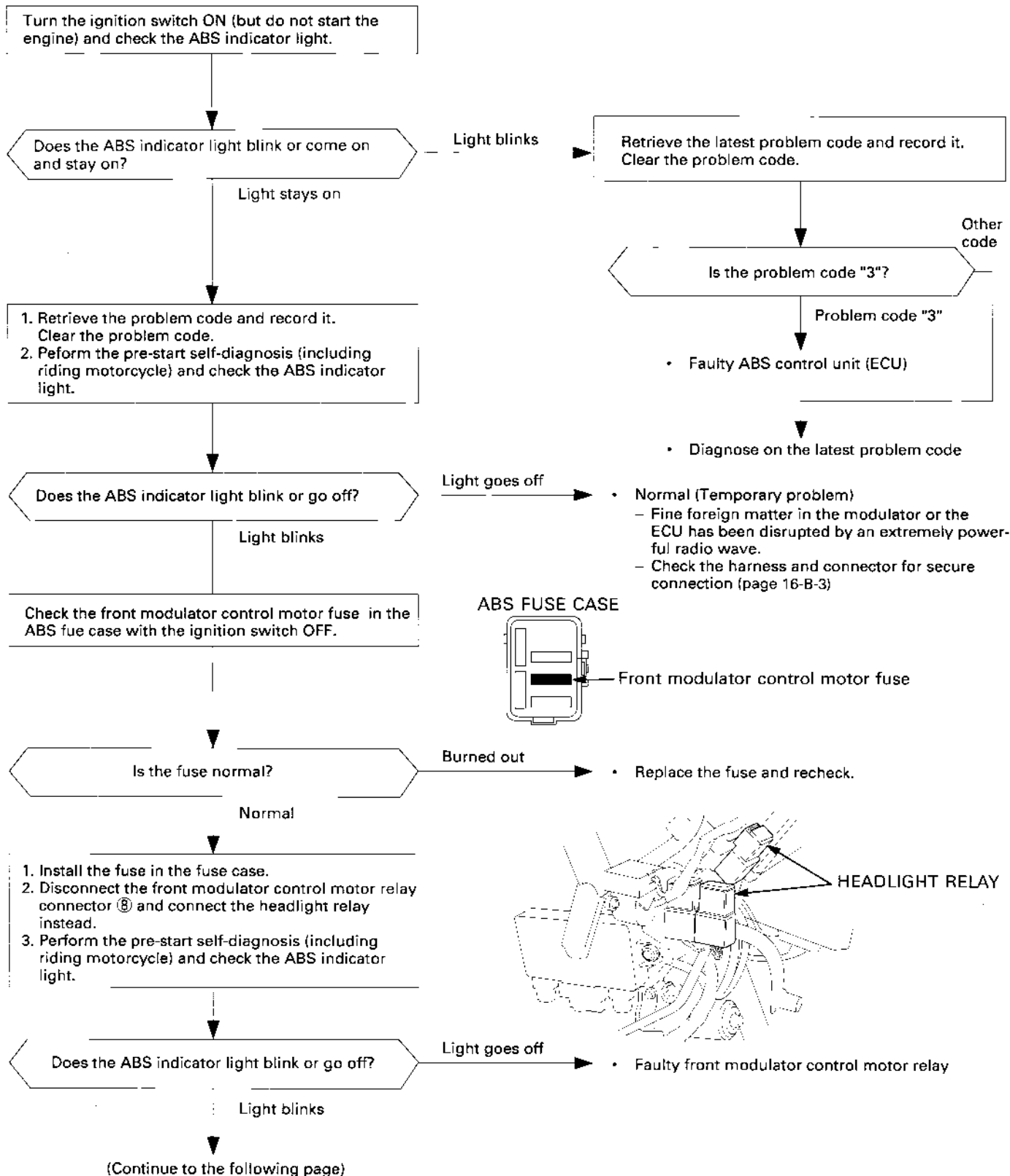

(From the previous page: Light blinks)

1. Disconnect the front modulator control motor relay connector ⑧ with the ignition switch OFF.
2. Check for voltage between the relay connector ⑧ terminal and body ground.

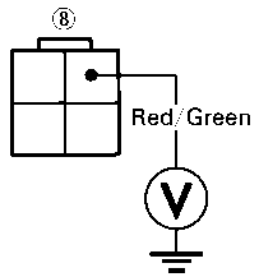

Does battery voltage register?

Voltage

No voltage

- Repair open in the Red or Red/Green harness between the front modulator control motor relay and battery.

1. Disconnect the motor driver Blue connector ⑰.
2. Check for continuity between the relay connector ⑧ and motor driver connector ⑰ terminals.

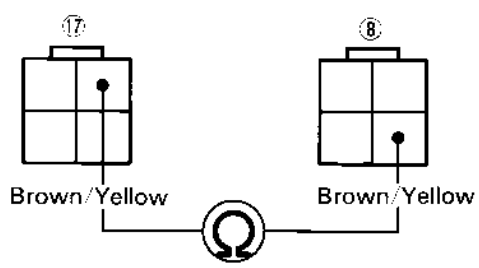

Is there continuity?

Continuity

No continuity

- Repair open in the Brown/Yellow harness between the front modulator control motor relay and motor driver.

- Check for voltage between the relay connector ⑧ terminal and body ground with the ignition switch ON.

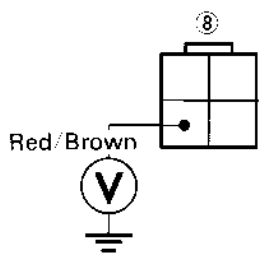

Does battery voltage register?

Voltage

No voltage

- Repair open in the Red/Brown harness between the fuse case and front modulator control motor relay.

1. Disconnect the White connector ⑬ of the ECU with the ignition switch OFF.
2. Check for continuity between the ECU connector ⑬ and relay connector ⑧ terminals.

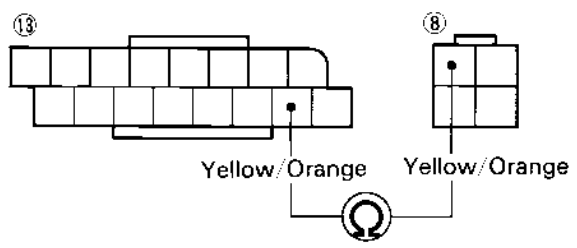

Is there continuity?

Continuity

No continuity

- Repair open in the Yellow/Orange harness between the ABS control unit (ECU) and front modulator control motor relay.

(Continue to the following page)

(From the previous page: Continuity)

1. Disconnect the front modulator control motor connector ⑭ of the front modulator.
2. Check for continuity between the motor connector ⑭ and motor driver connector ⑰ terminals.

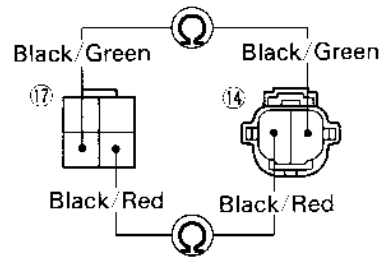

Is there continuity?

No continuity

- Repair open in the Black/Red or Black/Green harness between the front modulator (control motor) and motor driver.

Continuity

1. Check for continuity between the control motor connector ⑭ and body ground.

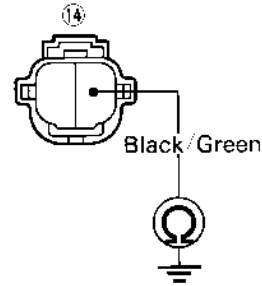

Is there continuity?

Continuity

- Repair short in the Black/Green harness between the front modulator (control motor) and motor driver.

No continuity

1. Disconnect the Black connector ⑫ of the ECU and motor driver 12P connector ⑯.
2. Check for continuity between the ECU connectors ⑫/⑬ and connector ⑯ terminals in the same harness colors.

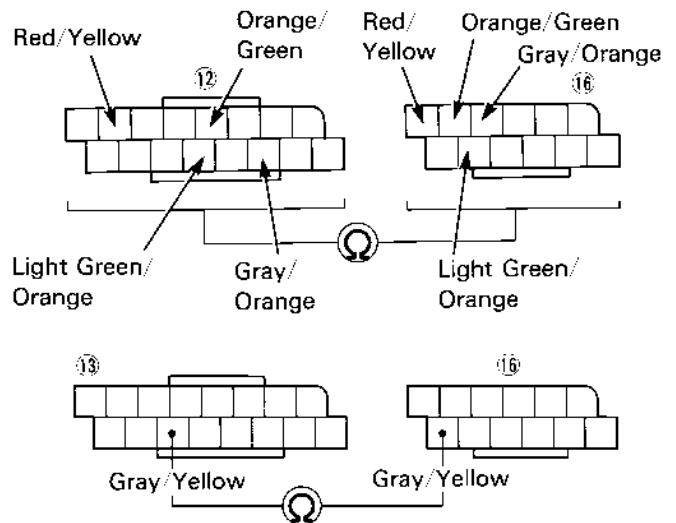

Is there continuity?

No continuity

- Repair open in the harness between the ABS control unit (ECU) and motor driver.

Continuity

(Continuity to the following page)

(From the previous page: Continuity)

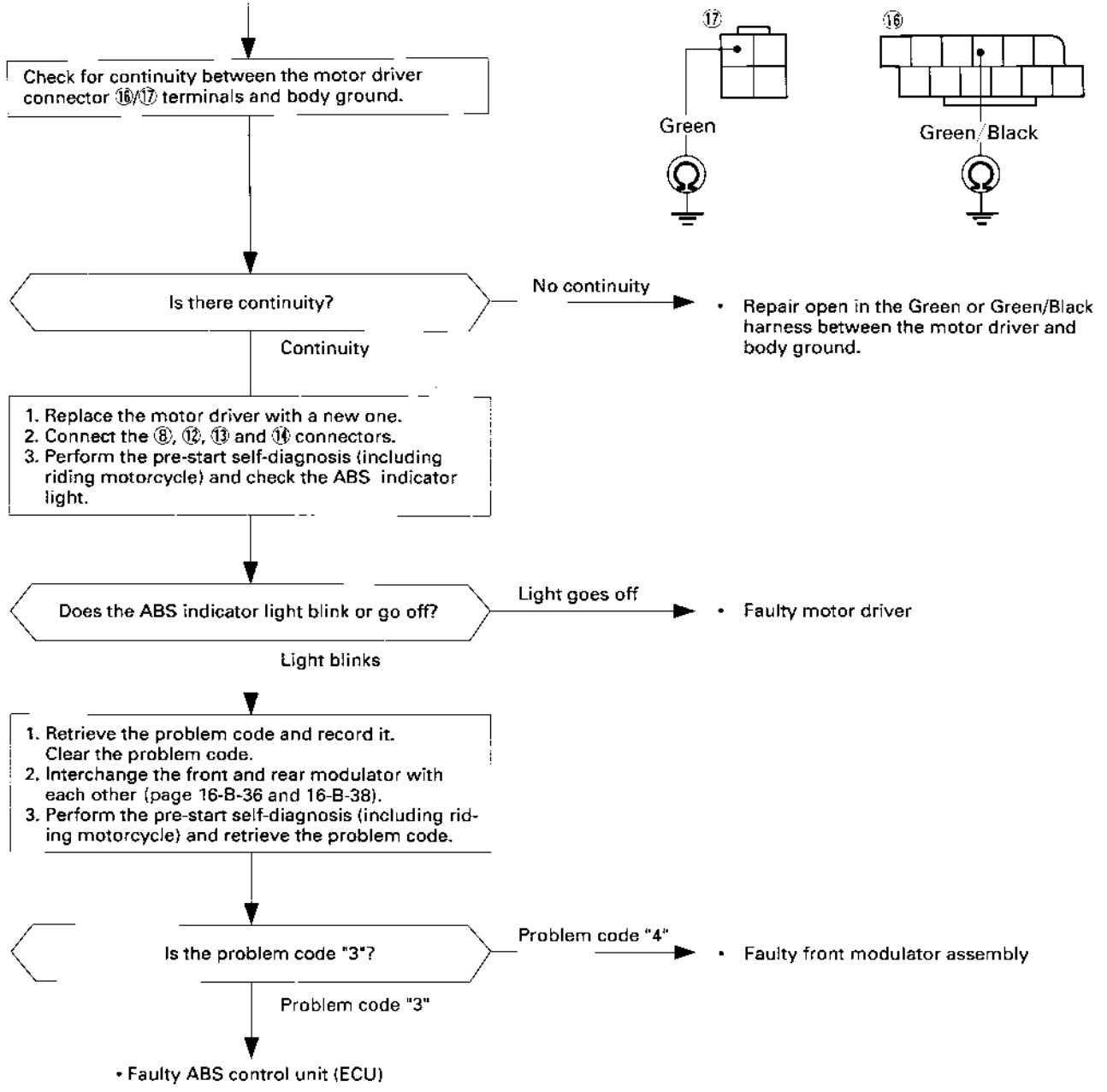

Problem code 4: Faulty rear modulator control motor system

Turn the ignition switch ON (but do not start the engine) and check the ABS indicator light.

Does the ABS indicator light blink or come on and stay on?

Continuity

1. Retrieve the problem code and record it. Clear the problem code.
2. Perform the pre-start self-diagnosis (including riding motorcycle) and check the ABS indicator light.

Does the ABS indicator light blink or go off?

Light blinks

Check the rear modulator control motor fuse in the ABS fuse case with the ignition switch OFF.

Is the fuse normal?

Normal

1. Install the fuse in the fuse case.
2. Disconnect the rear modulator control motor relay connector ⑨ and connect the headlight relay instead.
3. Perform the pre-start self-diagnosis (including riding motorcycle) and check the ABS indicator light.

Does the ABS indicator light blink or go off?

Light blinks

(Continue to the following page)

Light blinks

Retrieve the latest problem code and record it. Clear the problem code.

Is the problem code "4"?

Other code

Problem code "4"

- Faulty ABS control unit (ECU)

- Diagnose on the latest problem code
- Normal (Temporary problem)
 - Fine foreign matter in the modulator or the ECU has been disrupted by an extremely powerful radio wave.
 - Check the harness and connector for secure connection (page 16-B-3)

ABS FUSE CASE

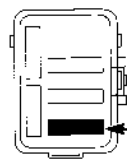

Rear modulator control motor fuse

Burned out

- Replace the fuse and recheck.

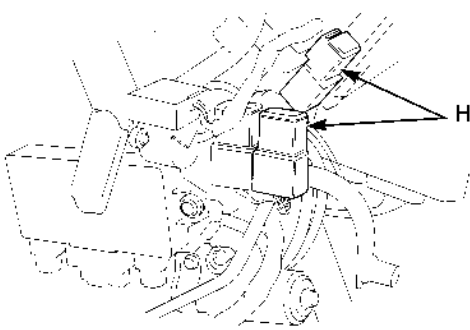

HEADLIGHT RELAY

Light goes off

- Faulty rear modulator control motor relay

(From the previous page: Light blinks)

1. Disconnect the rear modulator control motor relay connector ⑨ with the ignition switch OFF.
2. Check for voltage between the relay connector ⑨ terminal and body ground.

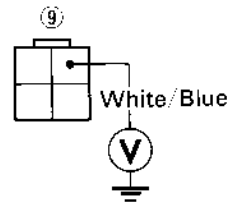

Does battery voltage register?

No voltage

- Repair open in the Red or White/Blue harness between the rear modulator control motor relay and battery.

Voltage

1. Disconnect the motor driver 4P Black connector ⑮.
2. Check for continuity between the relay connector ⑨ and motor driver connector ⑮ terminals.

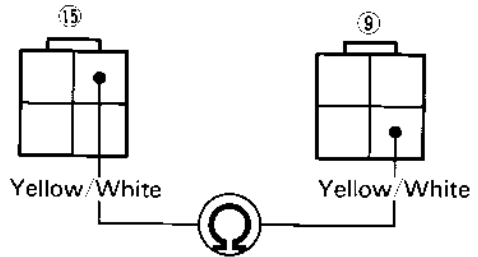

Is there continuity?

No continuity

- Repair open in the Yellow/White harness between the rear modulator control motor relay and motor driver.

Continuity

- Check for voltage between the relay connector ⑨ terminal and body ground with the ignition switch ON.

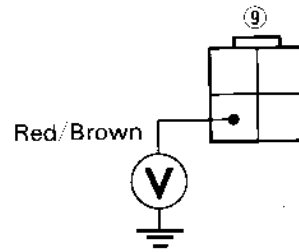

Does battery voltage register?

No voltage

- Repair open in the Red/Brown harness between the fuse case and rear modulator control motor relay.

Voltage

1. Disconnect the White connector ⑬ of the ECU with the ignition switch OFF.
2. Check for continuity between the ECU connector ⑬ and relay connector ⑨ terminals.

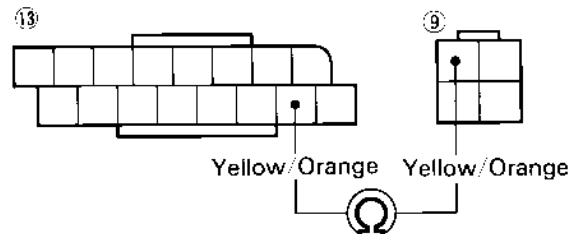

Is there continuity?

No continuity

- Repair open in the Yellow/Orange harness between the ABS control unit (ECU) and rear modulator control motor relay.

Continuity

(Continue to the following page)

(From the previous page: Continuity)

1. Disconnect the rear modulator control motor connector ⑱ of the rear modulator.
2. Check for continuity between the motor connector ⑱ and motor driver connector ⑮ terminals.

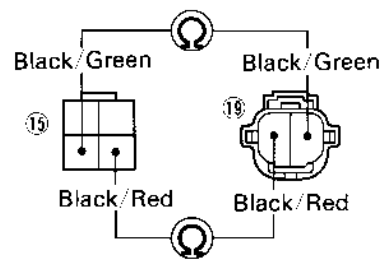

Is there continuity?

No continuity

- Repair open in the Black/Red or Black/Green harness between the rear modulator (control motor) and motor driver.

Continuity

- Check for continuity between the control motor connector ⑱ and body ground.

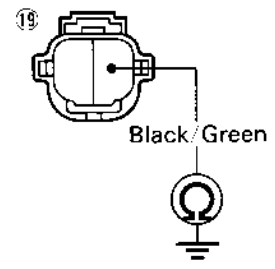

Is there continuity?

Continuity

- Repair short in the Black/Green harness between the rear modulator (control motor) and motor driver.

No continuity

1. Disconnect the Black connector ⑫ of the ECU and motor driver 12P connector ⑰.
2. Check for continuity between the ECU connectors ⑫/⑬ and connector ⑰ terminals in the same harness colors.

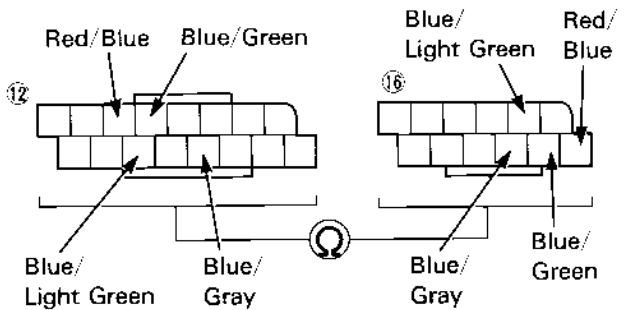

Is there continuity?

No continuity

- Repair open in the harness between the ABS control unit (ECU) and motor driver.

Continuity

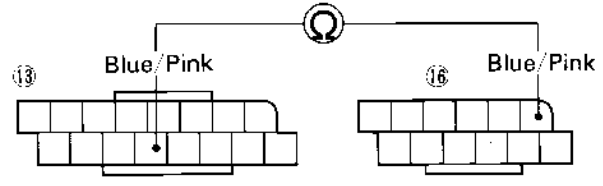

(Continue to the following page)

(From the previous page: Continuity)

Check for continuity between the motor driver connector ⑮/⑯ terminals and body ground.

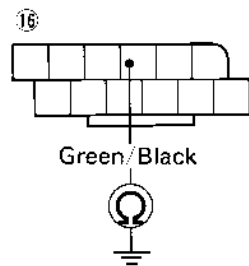
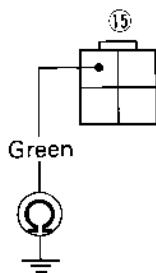

Is there continuity?

No continuity

- Repair open in the Green or Green/Black harness between the motor driver and body ground.

Continuity

1. Replace the motor driver with a new one.
2. Connect the ⑨, ⑫, ⑬ and ⑰ connectors.
3. Perform the pre-start self-diagnosis (including riding motorcycle) and check the ABS indicator light.

Does the ABS indicator light blink or go off?

Light goes off

- Faulty motor driver

Light blinks

1. Retrieve the problem code and record it. Clear the problem code.
2. Interchange the front and rear modulator with each other (page 16-B-36 and 16-B-38).
3. Perform the pre-start self-diagnosis (including riding motorcycle) and retrieve the problem code.

Is the problem code "4"?

Problem code "3"

- Faulty rear modulator assembly

Problem code "4"

- Faulty ABS control unit (ECU)

Problem code 5: Faulty front wheel speed sensor system

CAUTION

- When removing/installing the wheel speed sensor and wheel, take care not to damage the sensor and pulser ring.

NOTE

- Check the tire size and air pressure and check the tire for deformation before troubleshooting.
- The ABS indicator light might come on while riding under the following conditions. Turn the ignition switch OFF and perform the pre-start self-diagnosis. The ABS is normal if the indicator light goes off. However, the problem code is stored in the ECU. Ask the rider for the riding conditions in detail when the brings his motorcycle to your dealership for inspection.
 - The motorcycle has continuously run on bumpy road.
 - After riding on the road (after the pre-start self-diagnosis), the engine was kept running and the rear wheel turning (for more than 30 seconds) with the motorcycle placed on the center stand.

- Perform the inspection of the wheel speed sensor. Check the area around the wheel speed sensor as well.

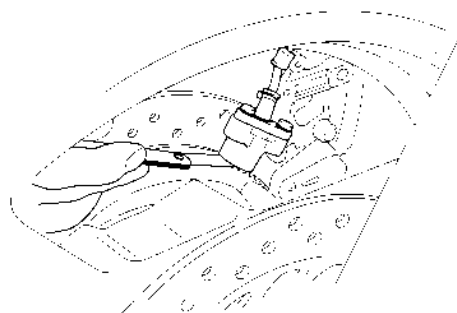

Place the motorcycle on its center stand and measure the air gap between the pulser ring and wheel speed sensor (page 16-B-34).
Standard: 0.4–0.5 mm (0.016–0.020 in)

Is the air gap correct?

Incorrect

- Check each part for deformation and looseness and correct accordingly. Recheck the air gap.

Correct

Is the pulser ring deformed or damaged (e.g. chipped teeth, etc.)?

Deformed and/or damaged

- Replace the pulser ring and recheck.

Not deformed and damaged

Is there iron or other magnetic deposits between the pulser ring and wheel speed sensor?

Deposits

- Remove the deposits and recheck.

No deposits

Are the pulser ring and sensor bracket loosely installed?

Loosely installed

- Correct deformation. Install securely and recheck.

Securely installed

(Continue to the following page)

NOTE

- Check the wheel speed sensor tip for damage. If it is damaged, replace with a new one and recheck the air gap.

(From the previous page)

1. Retrieve the problem code and record it.
Clear the problem code.
2. With the ignition switch in the ON position (do not operate the ignition switch after clearing the problem code), turn the front wheel (Vehicle speed: approximately 4 km/h [2.5 mile/h] or above) and check the ABS indicator light.

Does the ABS indicator light blink or stay on?

Light blinks (Sensor signal is input in the ECU)

- Normal (Temporary problem)
 - The ECU has been disrupted by an extremely powerful radio wave.
 - Check the harness and connector for secure connection at the wheel speed sensor system (page 23-117).

Light stays on

1. Disconnect the front wheel speed sensor connector ① with the ignition switch OFF.
2. Check for voltage between the main harness side terminals of the sensor connector ①.

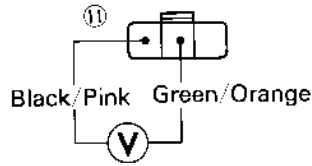

Does battery voltage register?

No voltage

- Repair open in the Black/Pink or Green/Orange harness between the wheel speed sensor and ABS control unit (ECU).

Voltage

1. Disconnect the White connector ⑬ of the ECU with the ignition switch OFF.
2. Check for continuity between the ECU ⑬ connector and sensor connector ① terminals.

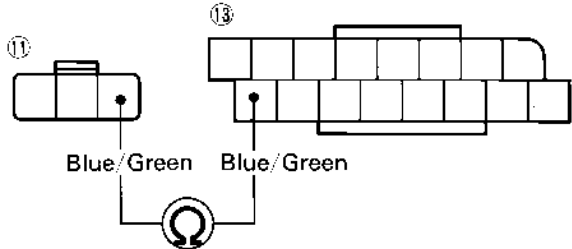

Is there continuity?

No continuity

- Repair open in the Blue/Green harness between the ABS control unit (ECU) and wheel speed sensor.

Continuity

(Continue to the following page)

(From the previous page)

1. Interchange the front and rear wheel speed sensor with each other.
2. Connect the ECU connector ⑬.
3. Perform the pre-start self-diagnosis (including riding motorcycle), then check the TCS indicator light.

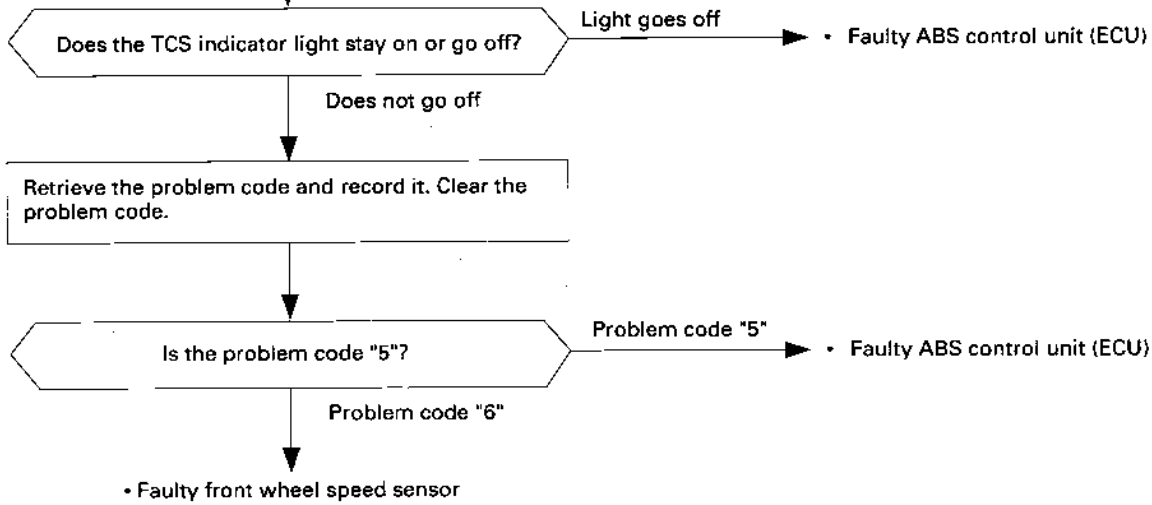
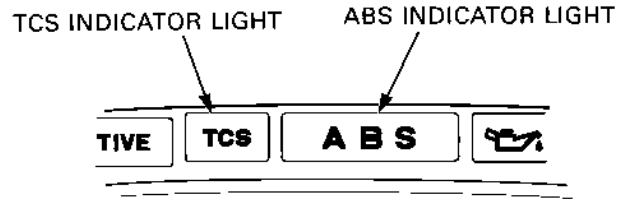

Problem code 6: Faulty rear wheel speed sensor system

CAUTION

• When removing/installing the wheel speed sensor and wheel, take care not to damage the sensor and pulser ring.

NOTE

• Check the tire size and air pressure and check the tire for deformation before troubleshooting.
• The ABS indicator light might come on while riding under the following conditions. Turn the ignition switch OFF and perform the pre-start self-diagnosis. The ABS is normal if the indicator light goes off. However, the problem code is stored in the ECU. Ask the rider for the riding conditions in detail when he brings his motorcycle to your dealership for inspection (Was the motorcycle continuously run on bumpy road?).

- Perform the inspection of the wheel speed sensor. Check the area around the wheel speed sensor as well.

Place the motorcycle on its center stand and measure the air gap between the pulser ring and wheel speed sensor (page 16-B-34).

Standard: $0.8 \begin{smallmatrix} +0.4 \\ -0.1 \end{smallmatrix}$ mm ($0.031 \begin{smallmatrix} +0.016 \\ -0.004 \end{smallmatrix}$ in)

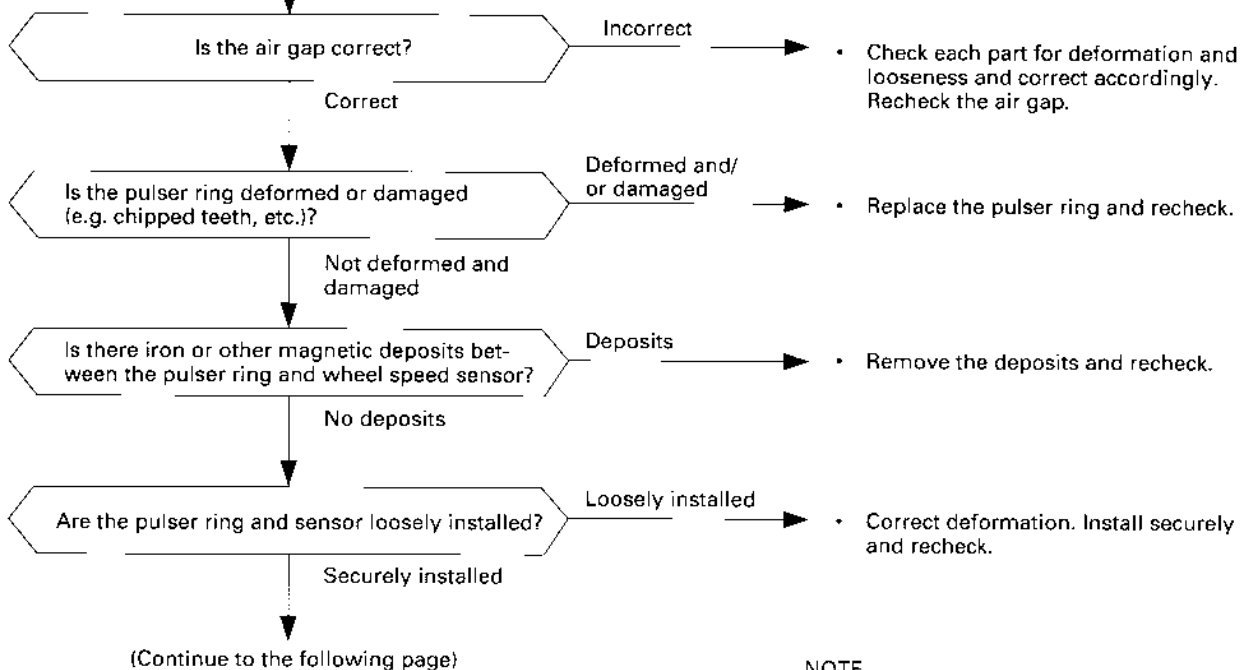
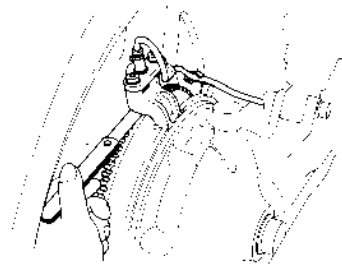

NOTE

• Check the wheel speed sensor tip for damage. If it is damaged, replace with a new one and recheck the air gap.

(From the previous page)

1. Retrieve the problem code and record it. Clear the problem code.
2. With the ignition switch in the ON position (do not operate the ignition switch after clearing the problem code), turn the rear wheel (Vehicle speed: approximately 4 km/h [2.5 mile/h] or above) and check the ABS indicator light.

Does the ABS indicator light blink or stay on?

Light blinks
(Sensor signal is input in the ECU)

- Normal (Temporary problem)
 - The ECU has been disrupted by an extremely powerful radio wave.
 - Check the harness and connector for secure connection at the wheel speed sensor system (page 16-B-3).

Light stays on

1. Disconnect the rear wheel speed sensor connector ⑱ with the ignition switch OFF.
2. Check for voltage between the main harness side terminals of the sensor connector ⑱.

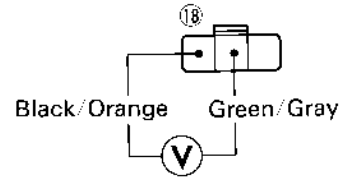

Does battery voltage register?

No voltage

- Repair open in the Black/Orange or Green/Gray harness between the wheel speed sensor and ABS control unit (ECU).

Voltage

1. Disconnect the White connector ⑲ of the ECU with the ignition switch OFF.
2. Check for continuity between the ECU ⑲ connector and sensor connector ⑱ terminals.

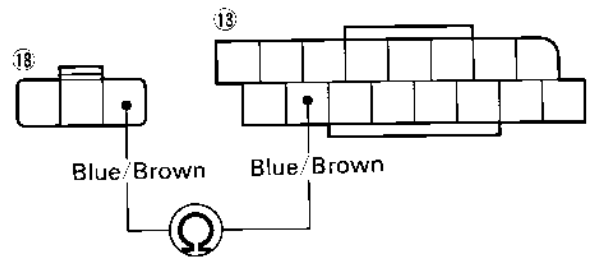

Is there continuity?

No continuity

- Repair open in the Blue/Brown harness between the ABS control unit (ECU) and wheel speed sensor.

Continuity

(Continue to the following page)

ABS (After '95)

(From the previous page)

1. Interchange the front and rear wheel speed sensor with each other.
2. Connect the ECU connector ⑬. Perform the pre-start self-diagnosis (including riding motorcycle), then check the TCS indicator light.

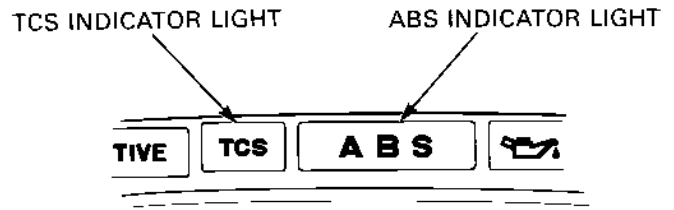

Does the TCS indicator light stay on or go off?

Light goes off

• Faulty ABS control unit (ECU)

Does not go off

Retrieve the problem code and record it. Clear the problem code.

Is the problem code "6"?

Problem code "6"

• Faulty ABS control unit (ECU)

Problem code "5"

• Faulty rear wheel speed sensor

Problem code 7: Faulty power circuit

NOTE

- Before starting the troubleshooting, check to see whether the idle speed conforms to the specified speed. If the idle speed is below specification, adjust idle speed.
- Ask the rider about the following when the motorcycle is brought in for inspection.
 - Ask whether the motorcycle has been run with electrical accessories.
 - Ask whether the motorcycle has been left for a long time with the ignition switch in the ON position. This problem code will light up to indicate battery discharge.

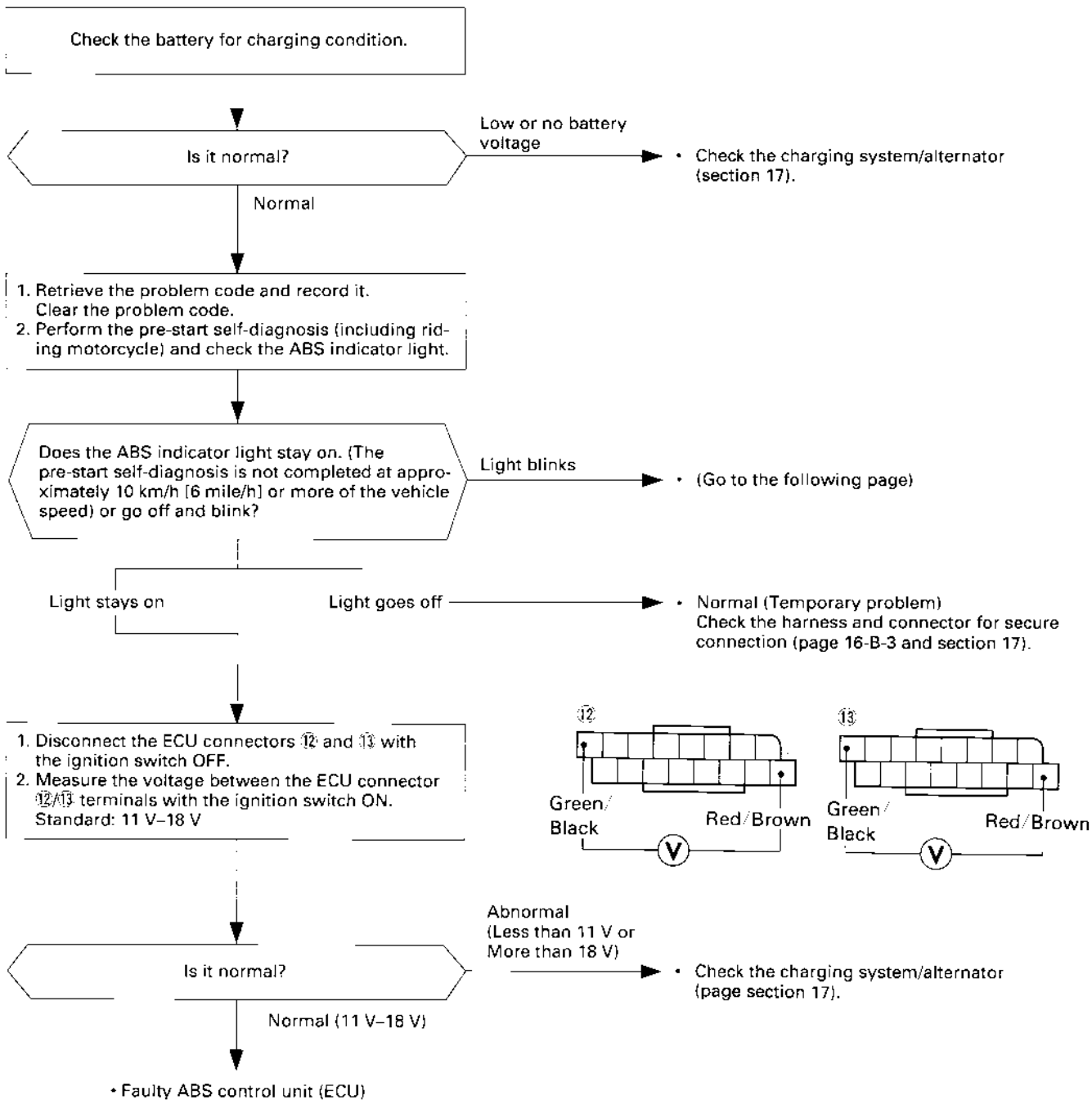

(From the previous page: Light blinks)

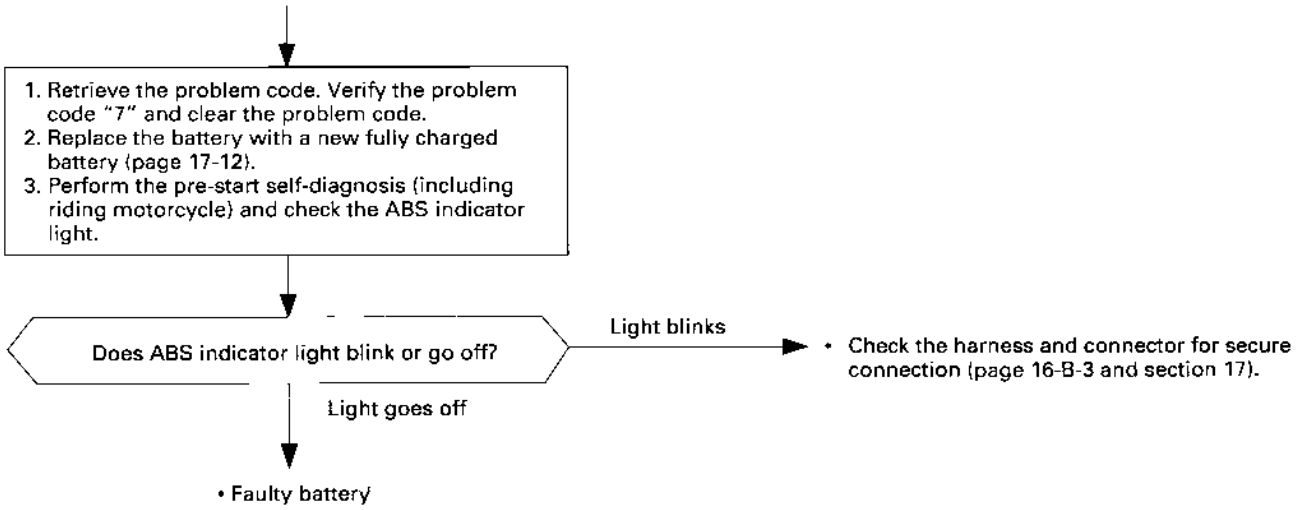

Problem code 8: Faulty ABS control unit (ECU)

NOTE

- The ABS indicator light blinks or comes on and stays on when the ECU has been disrupted by an extremely powerful radio wave (Electromagnetic interference). This is just a temporary symptom. Clear the problem code and the ECU is normal unless the symptom recurs. Ask the ride whether he used a radio apparatus or a security unit of a radio system when he brings his motorcycle to your dealership for inspection.

Turn the ignition switch ON (but do not start the engine) and check the ABS indicator light.

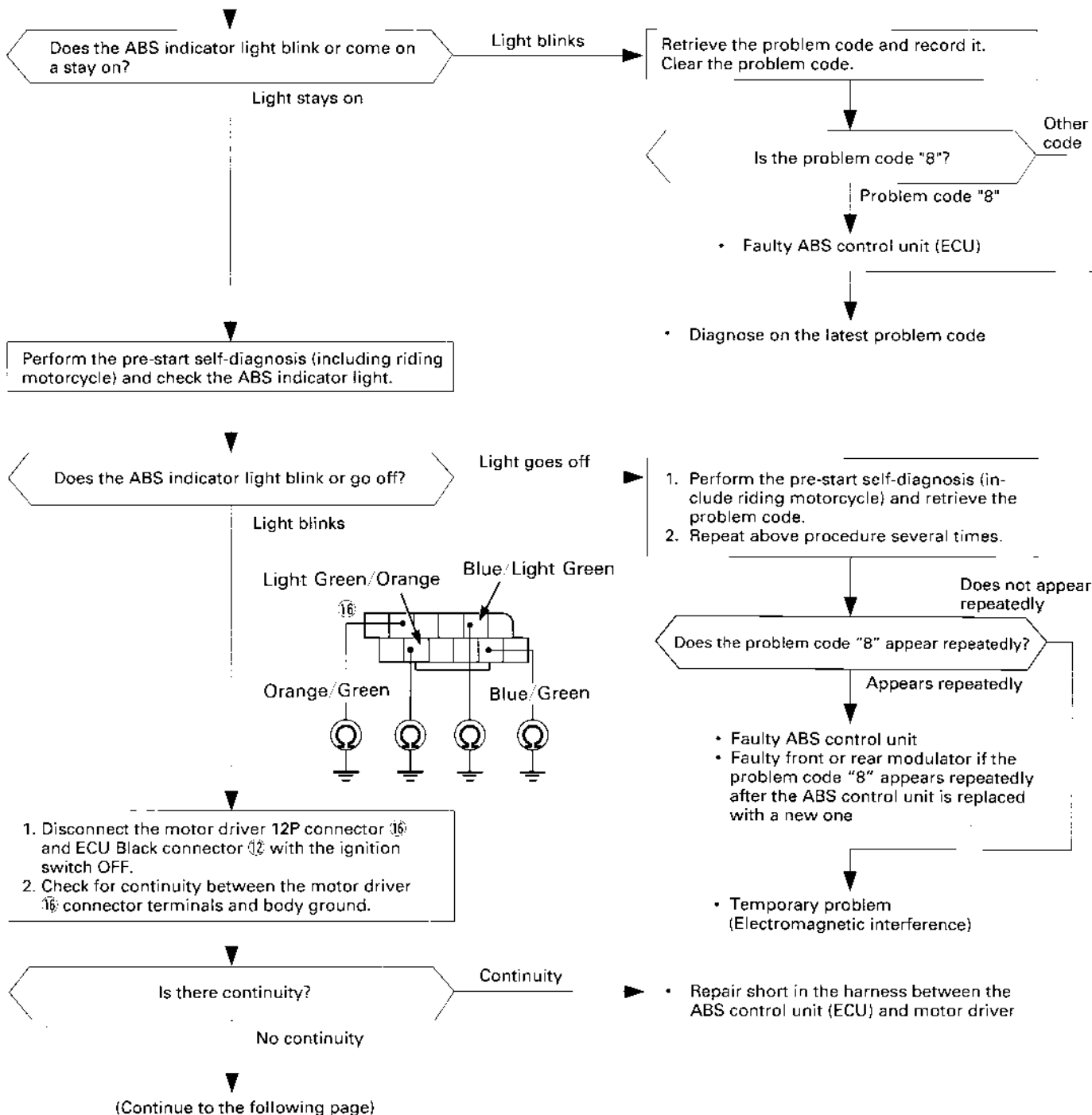

(From the previous page)



- 1. Connect the ECU connectors (12).
- 2. Replace the motor driver with a new one.
- 3. Retrieve the problem code and record it.
Clear the problem code.
- 4. Perform the pre-start self-diagnosis (including riding motorcycle) and check the ABS indicator light.

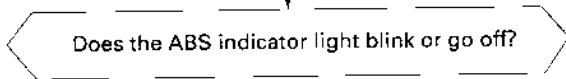

Light goes off



• Faulty motor driver

Light blinks



• Faulty ABS control unit (ECU)

Trouble not represented by a problem code: Faulty ABS indicator light

- When the clicking sound in the modulator control motor relay can be heard after turning the ignition switch ON, and where the ABS operates normally while riding:

- Before pre-start self-diagnosis (Ignition switch ON)

		ABS indicator light 2		
		ON	Blink	OFF
ABS indicator light 1	ON	Normal	A	A. B. F. E
	Blink	/	/	/
	OFF	D. G. I. J	D. G. I. J	D. E. F. G. I

- While riding

		ABS indicator light 2		
		ON	Blink	OFF
ABS indicator light 1	ON	/	/	I
	Blink	/	/	/
	OFF	/	A. C. I	Normal

- When there is no clicking sound in the modulator control motor relay after turning the ignition switch ON and the indicator light is faulty (i.e. pre-start self-diagnosis does not start).

- Before riding (with the engine started and the motorcycle parked)

		ABS indicator light 2		
		ON	Blink	OFF
ABS indicator light 1	ON	H. I. L	I	I
	Blink	I	/	I
	OFF	/	J. K	I

- While riding

		ABS indicator light 2		
		ON	Blink	OFF
ABS indicator light 1	ON	I. L	I	I
	Blink	I	H	I
	OFF	/	J. K	I

- A: Faulty indicator control unit
- B: Poor connection of the indicator control unit connector ③ (4P)
- C: Poor connection of the indicator control unit connector ③ (2P)
- D: Faulty ABS indicator light LED 1, poor connection of the connector ④
- E: Faulty ABS indicator light LED 2, poor connection of the connector ⑤
- F: Poor connection of the ABS indicator light connector ⑥
- G: Poor connection of the ABS indicator light connector ⑦
- H: Faulty indicator light switch, poor connection of the connector ②
- I: Faulty ABS ECU
- J: Poor connection of the ABS ECU connector ⑬
- K: Burned ABS main fuse (10A)
- L: Improper battery charge (See section 17.)

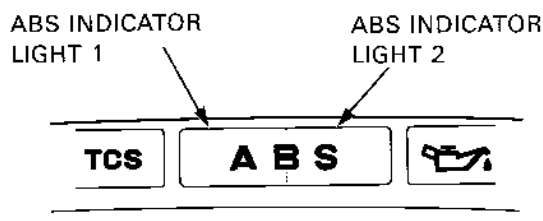

Wheel Speed Sensor Air Gap Inspection

Front

Raise the front wheel off the ground. Measure the air gap between the wheel speed sensor and pulser ring all the way around while rotating the front wheel by hand. It must be within the specification.

Standard: 0.4–0.5 mm (0.016–0.020 in)

Adjust by following procedure:
 Turn the front wheel so one of the poles of the pulser ring and sensor face each other.
 Insert a feeler gauge 0.5 mm between the sensor and pole, then hold the sensor lightly against the pole.
 Tighten the sensor bracket bolt.

Torque: 12 N-m(1.2 kg-m, 9 ft-lb)

Take off feeler gauge from the gap.
 Rotate the front wheel one full turn to make sure that the pulser ring does not interfere with the sensor.

If not still within specification, remove the sensor mounting bolts and perform the shim adjustment.
 Adjust the air gap again.

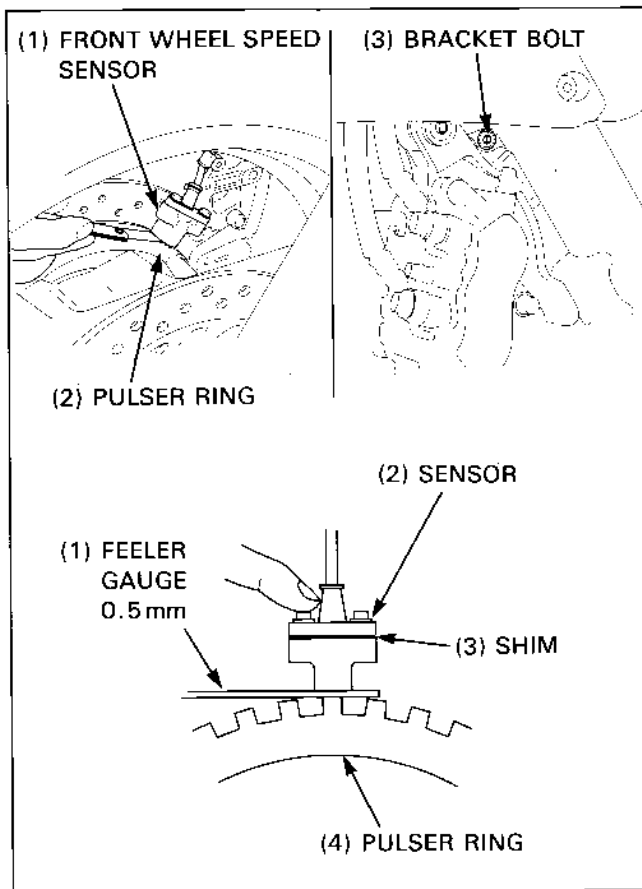

Rear

Place the motorcycle on its center stand. Measure the air gap between the wheel speed sensor and pulser ring all the way around while rotating the rear wheel by hand. It must be within the specification.

Standard: $0.8 \pm_{0.1}^{0.4}$ mm ($0.031 \pm_{0.004}^{0.016}$ in)

If not within specification, remove the sensor mounting bolts and perform the shim adjustment.
 Rotate the rear wheel one full turn to make sure that the pulser ring does not interfere with the sensor.

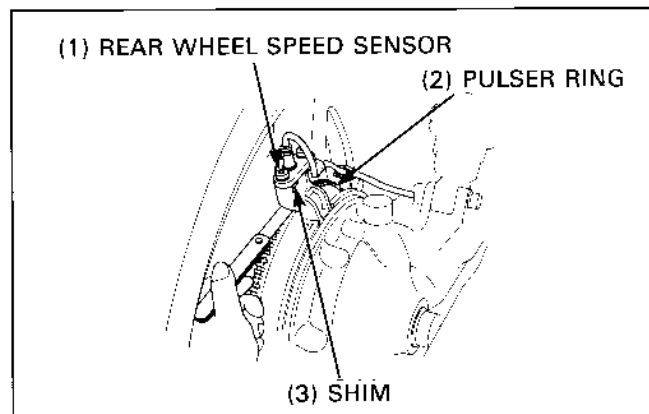

MEMO

Front Modulator Removal/Installation

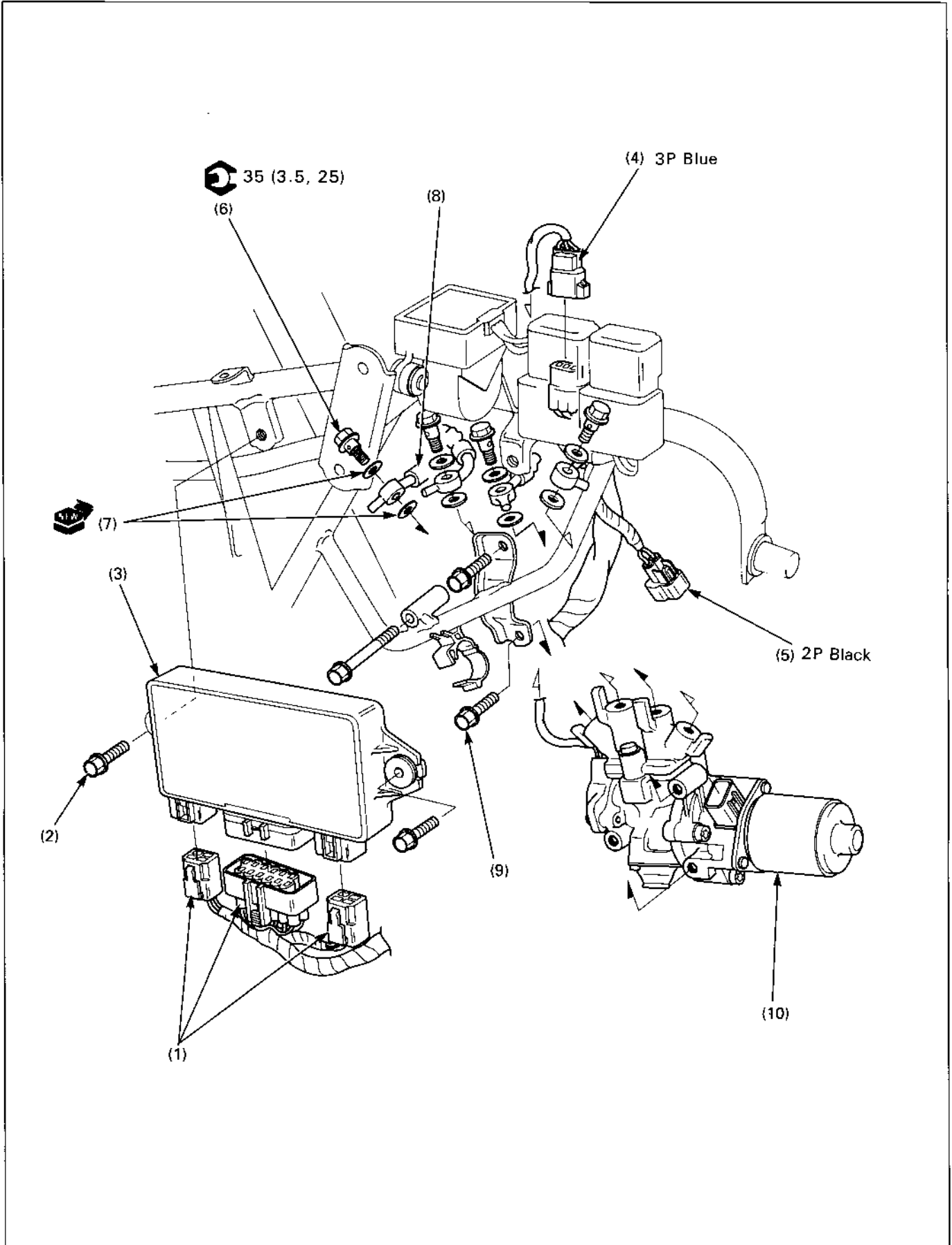

WARNING

- Check the brake system applying the lever and pedal brake after the air bleeding (page 3-13).

CAUTION

- Avoid spilling fluid on a painted, plastic, or rubber parts. Place a rag over these parts whenever system is serviced.
- When removing the oil bolts, cover the end of the brake hose to prevent contamination. Do not allow foreign material to enter the system.
- When removing and installing the modulator and motor driver, take care not to drop or strike the modulator.

NOTE

- Note that there is no brake fluid in the modulator (except in the modulator head), because the modulator is the motor-driven hydraulic pressure type. Therefore, brake fluid replacement and bleeding air from the modulator body is not necessary.
- Use only DOT 4 brake fluid from a sealed container.

Requisite Service

- Lever and pedal brake line fluid draining/air bleeding (page 15-2)
- Upper fairing removal/installation (page 2-9)

Procedure		Q'ty	Remarks
	Removal Order		Installation is in the reverse order of removal.
(1)	Motor driver connector	3	
(2)	Motor driver mounting bolt	2	
(3)	Motor driver	2	
(4)	Modulator crank angle sensor connector	1	
(5)	Modulator control motor connector	1	
(6)	Oil bolt	4	
(7)	Sealing washer	8	
(8)	Brake hose	4	NOTE • The reference numbers are stamped on each brake hose end and the modulator head. When installing, align each numbers (page 1-37)
(9)	Modulator mounting bolt	3	
(10)	Front modulator	1	CAUTION • Do not disassemble the modulator.

Rear Modulator Removal/Installation

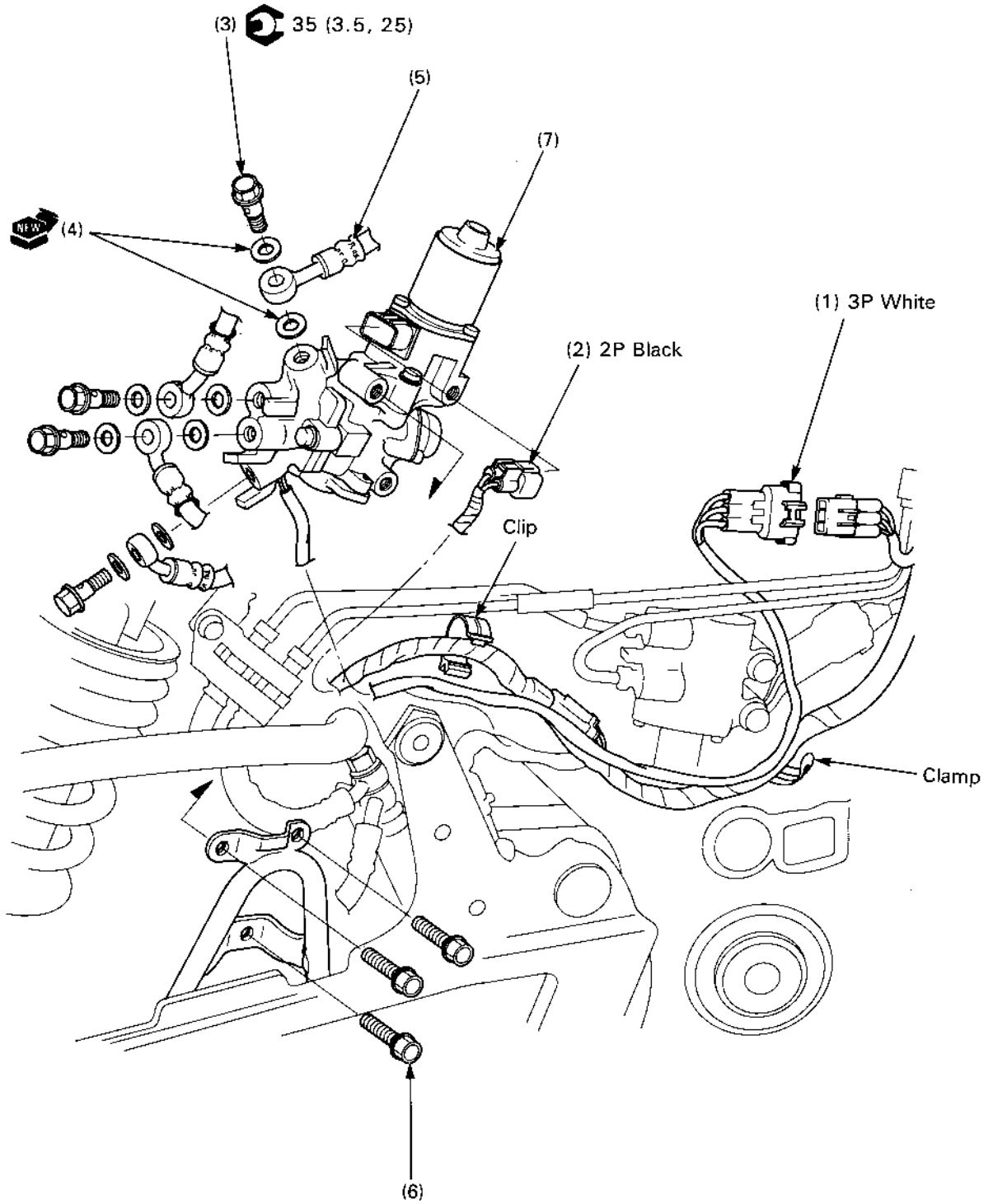

WARNING

- Check the brake system by applying the pedal brake after the air bleeding (page 3-13).

CAUTION

- Avoid spilling fluid on painted, plastic, or rubber parts. Place a rag over these parts whenever system is serviced.
- When removing the oil bolt, cover the end of the brake hose to prevent contamination. Do not allow foreign material to enter the system.
- When removing and installing the modulator, take care not to drop or strike the modulator.

NOTE

- Note that there is no brake fluid in the modulator (except in the modulator head), because the modulator is the motor-driven hydraulic pressure type. Therefore, brake fluid replacement and bleeding air from the modulator body is not necessary.
- Use only DOT 4 brake fluid from a sealed container.















Requisite Service

- Pedal brake line fluid draining/air bleeding (page 15-2)
- Right side cover removal/installation (page 2-2)

Procedure		Q'ty	Remarks
	Removal Order		
(1)	Modulator crank angle sensor connector	1	Installation is in the reverse order of removal. Remove the sensor wire from the clamp and clip.
(2)	Modulator control motor connector	1	
(3)	Oil bolt	4	
(4)	Sealing washer	8	
(5)	Brake hose	4	
			NOTE
			• The reference numbers are stamped on each brake hose end and the modulator head. When installing, align each numbers (page 1-41).
(6)	Modulator mounting bolt	3	CAUTION
(7)	Rear modulator	1	
			• Do not disassemble the modulator.

Symbols

The symbols used throughout this manual show specific service procedures. If supplementary information is required pertaining to these symbols, it would be explained specifically in the text without the use of the symbols.

	<p>Replace the part(s) with new one(s) before assembly.</p>
	<p>Use special tool</p>
	<p>Use optional tool. Use the same procedure you use to order parts.</p>
 <p>10 (1.0, 7.2)</p>	<p>Torque specification. 10 N·m (1.0 kg-m, 7.2 ft-lb)</p>
	<p>Use recommended engine oil, unless otherwise specified.</p>
	<p>Use molybdenum oil solution (mixture of the engine oil and molybdenum grease in a ratio of 1 : 1).</p>
	<p>Use multi-purpose grease (Lithium based multi-purpose grease NLGI #2 or equivalent)</p>
	<p>Use molybdenum disulfide grease (containing more than 3% molybdenum disulfide, NLGI #2 or equivalent) Example: Molykote® BR-2 plus manufactured by Dow Corning, U.S.A. Multi-purpose M-2 manufactured by Mitsubishi Oil Japan</p>
	<p>Use molybdenum disulfide paste (containing more than 40% molybdenum disulfide, NLGI #2 or equivalent) Example: Molykote® G-n Paste manufactured by Dow Corning, U.S.A. Honda Moly 60 (U.S.A. only) Rocol ASP manufactured by Rocol Limited, U.K. Rocol Paste manufactured by Sumico Lubricant, Japan</p>
	<p>Use silicone grease</p>
	<p>Apply a locking agent. Use a middle strength locking agent unless otherwise specified.</p>
	<p>Apply sealant</p>
	<p>Use brake fluid, DOT 3 or DOT 4. Use the recommended brake fluid, unless otherwise specified.</p>
	<p>Use Fork or Suspension Fluid.</p>